



4. If  $\alpha + i\beta$  and  $\gamma + i\delta$  are the roots of  $x^2 - (3-2i)x - (2i-2) = 0$ ,  $i = \sqrt{-1}$ , then  $\alpha\gamma + \beta\delta$  is equal to :

- (1) 6 (2) 2  
(3) -2 (4) -6

**Ans. (2)**

**Sol.**  $x^2 - (3-2i)x - (2i-2) = 0$

$$x = \frac{(3-2i) \pm \sqrt{(3-2i)^2 - 4(1)(-(2i-2))}}{2(1)}$$

$$= \frac{(3-2i) \pm \sqrt{9-4-12i+8i-8}}{2}$$

$$= \frac{3-2i \pm \sqrt{-3-4i}}{2}$$

$$= \frac{3-2i \pm \sqrt{(1)^2 + (2i)^2 - 2(1)(2i)}}{2}$$

$$= \frac{3-2i \pm (1-2i)}{2}$$

$$\Rightarrow \frac{3-2i+1-2i}{2} \text{ or } \frac{3-2i-1+2i}{2}$$

$$\Rightarrow 2-2i \text{ or } 1+0i$$

$$\text{So } \alpha\gamma + \beta\delta = 2(1) + (-2)(0) = 2$$

5. If the midpoint of a chord of the ellipse  $\frac{x^2}{9} + \frac{y^2}{4} = 1$  is  $(\sqrt{2}, 4/3)$ , and the length of the chord is  $\frac{2\sqrt{\alpha}}{3}$ , then  $\alpha$  is :

(1) 18 (2) 22  
(3) 26 (4) 20

**Ans. (2)**

**Sol.**

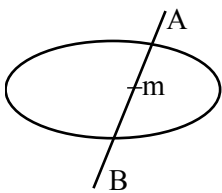

If  $m\left(\sqrt{2}, \frac{4}{3}\right)$  then equation of AB is

$$T = S_1$$

$$\frac{x\sqrt{2}}{9} + \frac{y}{4}\left(\frac{4}{3}\right) = \frac{(\sqrt{2})^2}{9} + \frac{\left(\frac{4}{3}\right)^2}{4}$$

$$\frac{\sqrt{2}x}{9} + \frac{y}{3} = \frac{2}{9} + \frac{4}{9}$$

$$\sqrt{2}x + 3y = 6 \Rightarrow y = \frac{6-\sqrt{2}x}{3} \text{ put in ellipse}$$

$$\text{So, } \frac{x^2}{9} + \frac{(6-\sqrt{2}x)^2}{9 \times 4} = 1$$

$$4x^2 + 36 + 2x^2 - 12\sqrt{2}x = 36$$

$$6x^2 - 12\sqrt{2}x = 0$$

$$6x(x-2\sqrt{2}) = 0$$

$$x = 0 \text{ \& } x = 2\sqrt{2}$$

$$\text{So } y = 2 \quad y = \frac{2}{3}$$

$$\text{Length of chord} = \sqrt{(2\sqrt{2}-0)^2 + \left(\frac{2}{3}-2\right)^2}$$

$$= \sqrt{8 + \frac{16}{9}}$$

$$= \sqrt{\frac{88}{9}} = \frac{2}{3}\sqrt{22} \text{ so } \boxed{\alpha = 22}$$

6. Let S be the set of all the words that can be formed by arranging all the letters of the word GARDEN. From the set S, one word is selected at random. The probability that the selected word will NOT have vowels in alphabetical order is :

(1)  $\frac{1}{4}$  (2)  $\frac{2}{3}$

(3)  $\frac{1}{3}$  (4)  $\frac{1}{2}$

**Ans. (4)**







14. Let  $f: [0, 3] \rightarrow A$  be defined by  $f(x) = 2x^3 - 15x^2 + 36x + 7$  and  $g: [0, \infty) \rightarrow B$  be defined by  $g(x) = \frac{x^{2025}}{x^{2025} + 1}$ . If both the functions are onto and  $S = \{x \in \mathbf{Z} : x \in A \text{ or } x \in B\}$ , then  $n(S)$  is equal to :

- (1) 30 (2) 36  
(3) 29 (4) 31

Ans. (1)

Sol. as  $f(x)$  is onto hence  $A$  is range of  $f(x)$

now  $f'(x) = 6x^2 - 30x + 36$

$= 6(x-2)(x-3)$

$f(2) = 16 - 60 + 72 + 7 = 35$

$f(3) = 54 - 135 + 108 + 7 = 34$

$f(0) = 7$

hence range  $\in [7, 35] = A$

also for range of  $g(x)$

$g(x) = 1 - \frac{1}{x^{2025} + 1} \in [0, 1) = B$

$s = \{0, 7, 8, \dots, 35\}$  hence  $n(s) = 30$

15. Let  $[x]$  denote the greatest integer less than or equal to  $x$ . Then domain of  $f(x) = \sec^{-1}(2[x]+1)$  is :

- (1)  $(-\infty, -1] \cup [0, \infty)$   
(2)  $(-\infty, -\infty)$   
(3)  $(-\infty, -1] \cup [1, \infty)$   
(4)  $(-\infty, \infty) - \{0\}$

Ans. (2)

Sol.  $2[x] + 1 \leq -1$  or  $2[x] + 1 \geq 1$

$\Rightarrow [x] \leq -1 \cup [x] \geq 0$

$\Rightarrow x \in (-\infty, 0) \cup x \in [0, \infty)$

$\Rightarrow x \in (-\infty, \infty)$

16. If  $\sum_{r=1}^{13} \left\{ \frac{1}{\sin\left(\frac{\pi}{4} + (r-1)\frac{\pi}{6}\right) \sin\left(\frac{\pi}{4} + \frac{r\pi}{6}\right)} \right\} = a\sqrt{3} + b,$

$a, b \in \mathbf{Z}$ , then  $a^2 + b^2$  is equal to :

- (1) 10 (2) 2  
(3) 8 (4) 4

Ans. (3)

Sol.  $\frac{1}{\sin \frac{\pi}{6}} \sum_{r=1}^{13} \frac{\sin \left[ \left( \frac{\pi}{4} + \frac{r\pi}{6} \right) - \left( \frac{\pi}{4} \right) - (r-1) \frac{\pi}{6} \right]}{\sin \left( \frac{\pi}{4} + (r-1) \frac{\pi}{6} \right) \sin \left( \frac{\pi}{4} + \frac{r\pi}{6} \right)}$

$\frac{1}{\sin \frac{\pi}{6}} \sum_{r=1}^{13} \left( \cot \left( \frac{\pi}{4} + (r-1) \frac{\pi}{6} \right) - \cot \left( \frac{\pi}{4} + \frac{r\pi}{6} \right) \right)$

$= 2\sqrt{3} - 2 = a\sqrt{3} + b$

So  $a^2 + b^2 = 8$

17. Two equal sides of an isosceles triangle are along  $-x + 2y = 4$  and  $x + y = 4$ . If  $m$  is the slope of its third side, then the sum, of all possible distinct values of  $m$ , is :

- (1) -6 (2) 12  
(3) 6 (4)  $-2\sqrt{10}$

Ans. (3)

Sol.

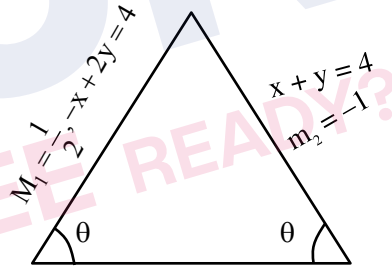

$\tan \theta = \frac{m - \frac{1}{2}}{1 + \frac{1}{2}m} = \frac{-1 - m}{1 - m} = \frac{m + 1}{m - 1}$

$\frac{2m - 1}{2 + m} = \frac{m + 1}{m - 1}$

$2m^2 - 3m + 1 = m^2 + 3m + 2$

$m^2 - 6m - 1 = 0$

sum of root = 6

sum is 6

18. Let the coefficients of three consecutive terms  $T_r$ ,  $T_{r+1}$  and  $T_{r+2}$  in the binomial expansion of  $(a + b)^{12}$  be in a G.P. and let p be the number of all possible values of r. Let q be the sum of all rational terms in the binomial expansion of  $(\sqrt[4]{3} + \sqrt[3]{4})^{12}$ . Then p + q is equal to :

- (1) 283                                      (2) 295  
(3) 287                                      (4) 299

Ans. (1)

Sol.  $(a + b)^{12}$

$T_r, T_{r+1}, T_{r+2} \rightarrow GP$

So,  $\frac{T_{r+1}}{T_r} = \frac{T_{r+2}}{T_{r+1}}$

$\frac{{}^{12}C_r}{{}^{12}C_{r-1}} = \frac{{}^{12}C_{r+1}}{{}^{12}C_r}$

$\frac{12-r+1}{r} = \frac{12-(r+1)+1}{r+1}$

$(13-r)(r+1) = (12-r)(r)$

$-r + 12r + 13 = 12r - r^2$

$13 = 0$

No value of r possible

So P = 0

$\left(3^{\frac{1}{4}} + 4^{\frac{1}{3}}\right)^{12} = \sum {}^{12}C_r \left(3^{\frac{1}{4}}\right)^{12-r} \left(4^{\frac{1}{3}}\right)^r$

Exponent of  $\left(3^{\frac{1}{4}}\right)$       exponent of  $\left(4^{\frac{1}{3}}\right)$       term

12                                      0                                      27

0                                      12                                      256

$q = 27 + 256 = 283$

$p + q = 0 + 283 = 283$

19. If A and B are the points of intersection of the circle  $x^2 + y^2 - 8x = 0$  and the hyperbola  $\frac{x^2}{9} - \frac{y^2}{4} = 1$  and a point P moves on the line  $2x - 3y + 4 = 0$ , then the centroid of  $\Delta PAB$  lies on the line :

- (1)  $4x - 9y = 12$   
(2)  $x + 9y = 36$   
(3)  $9x - 9y = 32$   
(4)  $6x - 9y = 20$

Ans. (4)

Sol.  $x^2 + y^2 - 8x = 0, \frac{x^2}{9} - \frac{y^2}{4} = 1$  .... (1)

$4x^2 - 9y^2 = 36$  ... (2)

Solve (1) & (2)

$4x^2 - 9(8x - x^2) = 36$

$13x^2 - 72x - 36 = 0$

$(13x + 6)(x - 6) = 0$

$x = \frac{-6}{13}, x = 6$

$x = \frac{-6}{13}$  (rejected)

y  $\rightarrow$  Imaginary

$n = 6, \frac{36}{9} - \frac{y^2}{4} = 1$

$y^2 = 12, y = \pm\sqrt{12}$

$A(6, \sqrt{12}), B(6, -\sqrt{12})$

$p\left(\alpha, \frac{2\alpha + 4}{3}\right)$  P lies on

centroid (h,k)                                       $2x - 3y + y = 0$

$h = \frac{12 + \alpha}{3}, \alpha = 3h - 12$

$k = \frac{2\alpha + 4}{3} \Rightarrow 2\alpha + 4 = 9k$

$\alpha = \frac{9k - 4}{2}$

$6h - 2y = 9k - 4$

$6x - 9y = 20$

20. Let  $f : \mathbf{R} - \{0\} \rightarrow (-\infty, 1)$  be a polynomial of degree 2, satisfying  $f(x)f\left(\frac{1}{x}\right) = f(x) + f\left(\frac{1}{x}\right)$ . If  $f(K) = -2K$ , then the sum of squares of all possible values of  $K$  is :

- (1) 1 (2) 6  
(3) 7 (4) 9

**Ans. (2)**

**Sol.** as  $f(x)$  is a polynomial of degree two let it be

$$f(x) = ax^2 + bx + c \quad (a \neq 0)$$

on satisfying given conditions we get

$$c = 1 \text{ \& } a = \pm 1$$

$$\text{hence } f(x) = 1 \pm x^2$$

also range  $\in (-\infty, 1]$  hence

$$f(x) = 1 - x^2$$

$$\text{now } f(k) = -2k$$

$$1 - k^2 = -2k \rightarrow k^2 - 2k - 1 = 0$$

let roots of this equation be  $\alpha$  &  $\beta$

$$\begin{aligned} \text{then } \alpha^2 + \beta^2 &= (\alpha + \beta)^2 - 2\alpha\beta \\ &= 4 - 2(-1) = 6 \end{aligned}$$

**SECTION-B**

21. The number of natural numbers, between 212 and 999, such that the sum of their digits is 15, is \_\_\_\_\_.

**Ans. (64)**

**Sol.**

x	y	z
---	---	---

$$\text{Let } x = 2 \Rightarrow y + z = 13$$

$$(4,9), (5,8), (6,7), (7,6), (8,5), (9,4), \rightarrow 6$$

$$\text{Let } x = 3 \rightarrow y + z = 12$$

$$(3,9), (4,8), \dots, (9,3) \rightarrow 7$$

$$\text{Let } x = 4 \rightarrow y + z = 11$$

$$(2,9), (3,8), \dots, (9,1) \rightarrow 9$$

$$\text{Let } x = 5 \rightarrow y + z = 10$$

$$(1,9), (2,8), \dots, (9,1) \rightarrow 10$$

$$\text{Let } x = 6 \rightarrow y + z = 9$$

$$(0,9), (1,8), \dots, (9,0) \rightarrow 9$$

$$\text{Let } x = 7 \rightarrow y + z = 8$$

$$(0,9), (1,7), \dots, (8,0) \rightarrow 9$$

$$\text{Let } x = 8 \rightarrow y + z = 7$$

$$(0,7), (1,6), \dots, (7,0) \rightarrow 8$$

$$\text{Let } x = 9 \rightarrow y + z = 6$$

$$(0,6), (1,5), \dots, (6,0) \rightarrow 7$$

$$\text{Total} = 6 + 7 + 8 + 9 + 10 + 9 + 8 + 7 = 64$$

22. Let  $f(x) = \lim_{n \rightarrow \infty} \sum_{r=0}^n \left( \frac{\tan(x/2^{r+1}) + \tan^3(x/2^{r+1})}{1 - \tan^2(x/2^{r+1})} \right)$ .

Then  $\lim_{x \rightarrow 0} \frac{e^x - e^{f(x)}}{x - f(x)}$  is equal to \_\_\_\_\_.

**Ans. (1)**

**Sol.**  $f(x) = \lim_{n \rightarrow \infty} \sum_{r=0}^n \left( \tan \frac{x}{2^r} - \tan \frac{x}{2^{r+1}} \right) = \tan x$

$$\begin{aligned} \lim_{x \rightarrow 0} \left( \frac{e^x - e^{\tan x}}{x - \tan x} \right) &= \lim_{x \rightarrow 0} e^{\tan x} \frac{(e^{x - \tan x} - 1)}{(x - \tan x)} \\ &= 1 \end{aligned}$$

23. The interior angles of a polygon with  $n$  sides, are in an A.P. with common difference  $6^\circ$ . If the largest interior angle of the polygon is  $219^\circ$ , then  $n$  is equal to \_\_\_\_\_.

**Ans. (20)**

**Sol.**  $\frac{n}{2}(2a + (n-1)6) = (n-2) \cdot 180^\circ$

$$an + 3n^2 - 3n = (n-2) \cdot 180^\circ \quad \dots(1)$$

Now according to question

$$a + (n-1)6^\circ = 219^\circ$$

$$\Rightarrow a = 225^\circ - 6n^\circ \quad \dots(2)$$

Putting value of  $a$  from equation (2) in (1)

We get

$$(225n - 6n^2) + 3n^2 - 3n = 180n - 360$$

$$\Rightarrow 2n^2 - 42n - 360 = 0$$

$$\Rightarrow n^2 - 21n - 180 = 0$$

$$n = 20, -6(\text{rejected})$$

24. Let A and B be the two points of intersection of the line  $y + 5 = 0$  and the mirror image of the parabola  $y^2 = 4x$  with respect to the line  $x + y + 4 = 0$ . If d denotes the distance between A and B, and a denotes the area of  $\Delta SAB$ , where S is the focus of the parabola  $y^2 = 4x$ , then the value of  $(a + d)$  is \_\_\_\_\_.

Ans. (14)

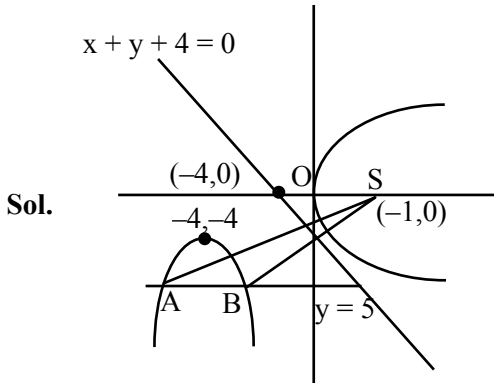

$$\text{Area} = \frac{1}{2} \times 4 \times 5 = 10 = a$$

$$6 = 4$$

$$\text{So } a + d = 14$$

25. If  $y = y(x)$  is the solution of the differential equation,

$$\sqrt{4-x^2} \frac{dy}{dx} = \left( \left( \sin^{-1} \left( \frac{x}{2} \right) \right)^2 - y \right) \sin^{-1} \left( \frac{x}{2} \right),$$

$$-2 \leq x \leq 2, y(2) = \left( \frac{\pi^2 - 8}{4} \right), \text{ then } y^2(0) \text{ is equal to}$$

Ans. (4)

Sol. 
$$\frac{dy}{dx} + \frac{\left( \sin^{-1} \frac{x}{2} \right)}{\sqrt{4-x^2}} y = \frac{\left( \sin^{-1} \frac{x}{2} \right)^3}{\sqrt{4-x^2}}$$

$$y e^{\frac{\left( \sin^{-1} \frac{x}{2} \right)^2}{2}} = \int \frac{\left( \sin^{-1} \frac{x}{2} \right)^3}{4-x^2} e^{\frac{\left( \sin^{-1} \frac{x}{2} \right)^2}{2}} dx$$

$$y = \left( \sin^{-1} \frac{x}{2} \right)^2 - 2 + c \cdot e^{-\frac{\left( \sin^{-1} \frac{x}{2} \right)^2}{2}}$$

$$y(2) = \frac{\pi^2}{4} - 2 \Rightarrow c = 0$$

$$y(0) = -2$$

**JEE-MAIN EXAMINATION – JANUARY 2025**

**(HELD ON TUESDAY 28<sup>th</sup> JANUARY 2025)**

**TIME : 3:00 PM TO 06:00 PM**

**PHYSICS**

**TEST PAPER WITH SOLUTION**

**SECTION-A**

26. A uniform magnetic field of 0.4 T acts perpendicular to a circular copper disc 20 cm in radius. The disc is having a uniform angular velocity of  $10\pi \text{ rad s}^{-1}$  about an axis through its centre and perpendicular to the disc. What is the potential difference developed between the axis of the disc and the rim ? ( $\pi = 3.14$ )

- (1) 0.0628 V                      (2) 0.5024 V  
(3) 0.2512 V                      (4) 0.1256 V

**Ans. (3)**

**Sol.**  $B = 0.4 \text{ T}$   
 $r = 20 \text{ cm}$   
 $\omega = 10\pi \text{ rad/s}$   
 $E = \frac{1}{2} B\omega R^2$   
 $= 0.2512 \text{ V}$

27. A parallel plate capacitor of capacitance  $1 \mu\text{F}$  is charged to a potential difference of 20 V. The distance between plates is  $1 \mu\text{m}$ . The energy density between plates of capacitor is :

- (1)  $1.8 \times 10^3 \text{ J/m}^3$                       (2)  $2 \times 10^{-4} \text{ J/m}^3$   
(3)  $2 \times 10^2 \text{ J/m}^3$                       (4)  $1.8 \times 10^5 \text{ J/m}^3$

**Ans. (1)**

**Sol.**  $C = 1 \mu\text{F}$   
 $V = 20 \text{ V}$   
 $d = 1 \mu\text{m}$   
Energy density  $= \frac{1}{2} \epsilon_0 E^2$   
 $E = \frac{V}{d} = 20 \times 10^6 \text{ V/m}$   
 $U = 1.77 \times 10^3 \text{ J/m}^3$

28. Match List-I with List-II

List-I	List-II
(A) Angular Impulse	(I) $[M^0 L^2 T^{-2}]$
(B) Latent Heat	(II) $[M L^2 T^{-3} A^{-1}]$
(C) Electrical resistivity	(III) $[M L^2 T^{-1}]$
(D) Electromotive force	(IV) $[M L^3 T^{-3} A^{-2}]$

Choose the **correct** answer from the options given below :

- (1) (A)-(III), (B)-(I), (C)-(IV), (D)-(II)  
(2) (A)-(I), (B)-(III), (C)-(IV), (D)-(II)  
(3) (A)-(III), (B)-(I), (C)-(II), (D)-(IV)  
(4) (A)-(II), (B)-(I), (C)-(IV), (D)-(III)

**Ans. (1)**

**Sol.** Angular impulse  $= [M L^2 T^{-1}]$   
Latent Heat  $= [M^0 L^2 T^{-2}]$   
Electrical resistivity  $= [M L^3 T^{-3} A^{-2}]$   
Electromotive force  $= [M L^2 T^{-3} A^{-1}]$

29. The ratio of vapour densities of two gases at the same temperature is  $\frac{4}{25}$ , then the ratio of r.m.s. velocities will be :

- (1)  $\frac{25}{4}$                                       (2)  $\frac{2}{5}$   
(3)  $\frac{5}{2}$                                       (4)  $\frac{4}{25}$

**Ans. (3)**

**Sol.**  $\frac{\rho_1}{\rho_2} = \frac{4}{25}$   
Ratio of rms velocities  $= \sqrt{\frac{\rho_2}{\rho_1}} = \frac{5}{2}$

- 30.** The kinetic energy of translation of the molecules in 50g of CO<sub>2</sub> gas at 17°C is :
- (1) 3986.3 J                      (2) 4102.8 J  
(3) 4205.5 J                      (4) 3582.7 J

**Ans. (2)**

**Sol.**  $(KE)_{\text{Translational}} = \left[ \frac{3}{2}KT \right] \times \text{no. of molecule}$

No. of molecule =  $\left[ \frac{50}{44} \times 6.023 \times 10^{23} \right]$

$(KE)_{\text{Translational}} = 4108.644 \text{ J}$

- 31.** In a long glass tube, mixture of two liquids A and B with refractive indices 1.3 and 1.4 respectively, forms a convex refractive meniscus towards A. If an object placed at 13 cm from the vertex of the meniscus in A forms an image with a magnification of '-2' then the radius of curvature of meniscus is :

- (1) 1 cm                              (2)  $\frac{1}{3}$  cm  
(3)  $\frac{2}{3}$  cm                              (4)  $\frac{4}{3}$  cm

**Ans. (3)**

**Sol.**

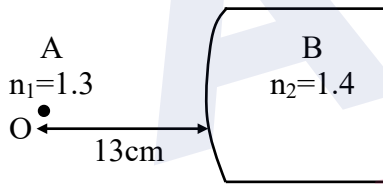

$$\frac{n_2}{v} - \frac{n_1}{u} = \frac{n_2 - n_1}{R}$$

$$\frac{1.4}{v} - \frac{1.3}{-13} = \frac{0.1}{R}$$

$$\frac{1.4}{v} = \frac{1-R}{10R}$$

$$\frac{1.4}{v} = \frac{1-R}{10R}$$

$$m = \frac{v/n_2}{u/n_1}$$

$$-2 \times \frac{(-13)}{1.3} = \frac{10R}{1-R}$$

$$R = \frac{2}{3} \text{ cm}$$

- 32.** The frequency of revolution of the electron in Bohr's orbit varies with n, the principal quantum number as

- (1)  $\frac{1}{n}$                                       (2)  $\frac{1}{n^3}$   
(3)  $\frac{1}{n^4}$                                       (4)  $\frac{1}{n^2}$

**Ans. (2)**

**Sol.** Frequency of revolution  $\propto \frac{1}{n^3}$

- 33.** Which of the following phenomena can not be explained by wave theory of light ?

- (1) Reflection of light  
(2) Diffraction of light  
(3) Refraction of light  
(4) Compton effect

**Ans. (4)**

**Sol.** Compton effect is based on particle nature of light.

- 34.** The velocity-time graph of an object moving along a straight line is shown in figure. What is the distance covered by the object between t = 0 to t = 4s ?

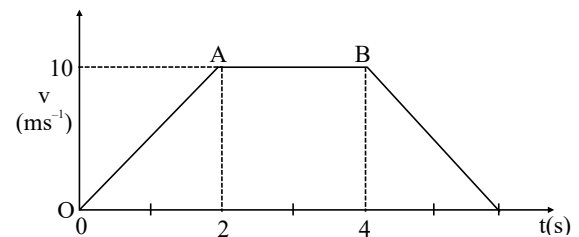

- (1) 30 m                                      (2) 10 m  
(3) 13 m                                      (4) 11 m

**Ans. (1)**

**Sol.** Distance = Area under v v/s t graph

$$\text{Distance} = \frac{1}{2} \times 2 \times 10 + 2 \times 10 = 30\text{m}$$

35.

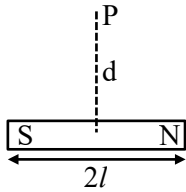

A bar magnet has total length  $2l = 20$  units and the field point P is at a distance  $d = 10$  units from the centre of the magnet. If the relative uncertainty of length measurement is 1%, then uncertainty of the magnetic field at point P is :

- (1) 10%                                      (2) 4%  
(3) 3%                                         (4) 5%

Ans. (2,3)

Sol. Method-1 :

Without considering uncentainty in  $\ell$ .

$$B = \frac{\mu_0 m}{4\pi r^3}$$

$$B \propto \frac{1}{r^3}$$

$$\frac{\Delta B}{B} = 3 \times \left( \frac{\Delta r}{r} \right)$$

% uncertainty in B = 3%

Method-2 :

With considering uncentainty in  $\ell$ .

$$B \propto \frac{1}{r^3}$$

$$\frac{\Delta B}{B} = \frac{\Delta \ell}{\ell} + 3 \times \left( \frac{\Delta r}{r} \right) = 1 + 3 \times 1 = 4\%$$

% uncertainty in B = 4%

36. Earth has mass 8 times and radius 2 times that of a planet. If the escape velocity from the earth is 11.2 km/s, the escape velocity in km/s from the planet will be :

- (1) 11.2                                        (2) 5.6  
(3) 2.8                                         (4) 8.4

Ans. (2)

Sol.  $V_{\text{escape}} = \sqrt{\frac{2GM}{R}}$

$$\frac{(V_{\text{escape}})_{\text{Planet}}}{(V_{\text{escape}})_{\text{Earth}}} = \sqrt{\left( \frac{M_P}{M_E} \right) \times \left( \frac{R_E}{R_P} \right)} = \frac{1}{2}$$

$$(V_{\text{escape}})_{\text{Planet}} = \frac{1}{2} (V_{\text{escape}})_{\text{Earth}} = 5.6 \text{ km/s}$$

37. Given below are two statements. One is labelled as **Assertion (A)** and the other is labelled as **Reason (R)**.

**Assertion (A)** : Knowing initial position  $x_0$  and initial momentum  $p_0$  is enough to determine the position and momentum at any time  $t$  for a simple harmonic motion with a given angular frequency  $\omega$ .

**Reason (R)** : The amplitude and phase can be expressed in terms of  $x_0$  and  $p_0$ .

In the light of the above statements, choose the **correct** answer from the options given below :

- (1) Both (A) and (R) are true but (R) is NOT the correct explanation of (A).  
(2) (A) is false but (R) is true.  
(3) (A) is true but (R) is false.  
(4) Both (A) and (R) are true and (R) is the correct explanation of (A).

Ans. (4)

Sol.  $x = A \sin(\omega t + \phi)$

$$x_0 = A \sin \phi \quad \dots(1)$$

$$p = mA\omega \cos(\omega t + \phi)$$

$$p_0 = mA\omega \cos \phi \quad \dots(2)$$

$$(2)/(1) \Rightarrow \tan \phi = \left( \frac{x_0}{p_0} \right) m\omega$$

$$\sin \phi = \frac{x_0 m\omega}{\sqrt{(m\omega x_0)^2 + p_0^2}}$$

$$\text{From (1), } A = \frac{x_0}{\sin \phi} = \frac{\sqrt{(m\omega x_0)^2 + p_0^2}}{m\omega}$$

This means we can explain assertion with the given reason.

38. A concave mirror produces an image of an object such that the distance between the object and image is 20 cm. If the magnification of the image is '-3', then the magnitude of the radius of curvature of the mirror is :

- (1) 3.75 cm                                      (2) 30 cm  
(3) 7.5 cm                                        (4) 15 cm

Ans. (4)

Sol.

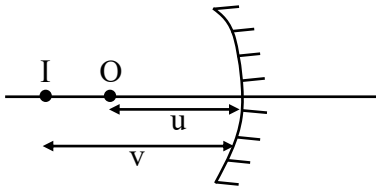

$$m = -3 = -\frac{v}{u} \text{ and } v - u = 20 \text{ cm}$$

$$f = \frac{vu}{v+u} = \frac{(-30)(-10)}{-30-10}$$

$$\therefore R = +15$$

39. A body of mass 4 kg is placed on a plane at a point P having coordinate (3, 4) m. Under the action of force  $\vec{F} = (2\hat{i} + 3\hat{j})\text{N}$ , it moves to a new point Q having coordinates (6, 10)m in 4 sec. The average power and instantaneous power at the end of 4 sec are in the ratio of :

- (1) 13 : 6                                      (2) 6 : 13  
(3) 1 : 2                                         (4) 4 : 3

Ans. (2)

Sol.  $\langle P \rangle = \frac{(2\hat{i} + 3\hat{j}) \cdot (3\hat{i} + 6\hat{j})}{4} = 6$

$$\vec{a} = \left( \frac{\vec{F}}{m} = \frac{1}{2}\hat{i} + \frac{3}{4}\hat{j} \right)$$

$$\vec{v} \text{ at } t = 4 \text{ sec} = \left( \frac{1}{2}\hat{i} + \frac{3}{4}\hat{j} \right) \times 4 = (2\hat{i} + 3\hat{j})$$

$$P_{\text{ins}} = (2\hat{i} + 3)(2\hat{i} + 3\hat{j}) = 13$$

$$\frac{\langle P \rangle}{P_{\text{ins}}} = \frac{6}{13}$$

Note : Given data is not matching.

$$S = ut + \frac{1}{2}at^2$$

$$S = 0 + \frac{1}{2} \frac{(2\hat{i} + 3\hat{j})}{4} (4)^2 = 4\hat{i} + 6\hat{j}$$

$$\text{If } \vec{r}_i = 3\hat{i} + 4\hat{j} \text{ then } \vec{r}_f = 7\hat{i} + 10\hat{j}$$

But Final position given in the question is (6, 10).

40.

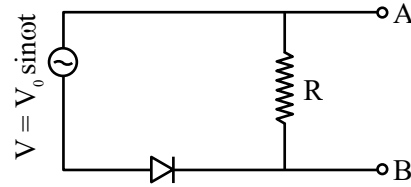

In the circuit shown here, assuming threshold voltage of diode is negligibly small, then voltage  $V_{AB}$  is correctly represented by :

(1)  $V_{AB}$  would be zero at all times

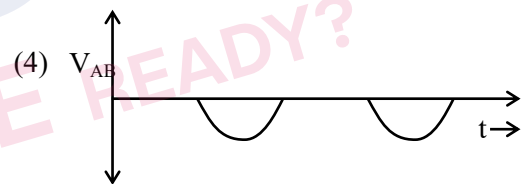
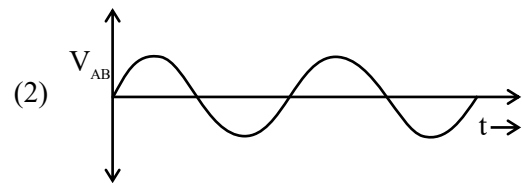

Ans. (4)

Sol.  $V = V_0 \sin \omega t$

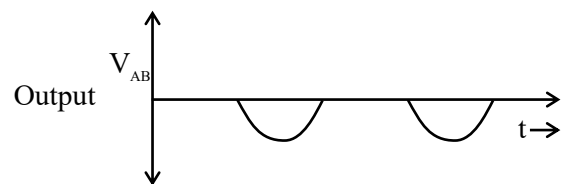
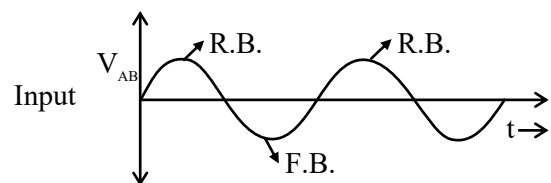

41.

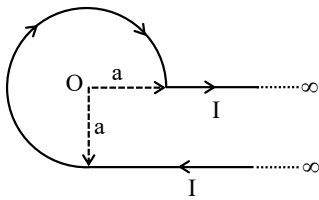

An infinite wire has a circular bend of radius  $a$ , and carrying a current  $I$  as shown in figure. The magnitude of magnetic field at the origin  $O$  of the arc is given by :

(1)  $\frac{\mu_0 I}{4\pi a} \left[ \frac{\pi}{2} + 1 \right]$       (2)  $\frac{\mu_0 I}{4\pi a} \left[ \frac{3\pi}{2} + 1 \right]$

(3)  $\frac{\mu_0 I}{2\pi a} \left[ \frac{\pi}{2} + 2 \right]$       (4)  $\frac{\mu_0 I}{4\pi a} \left[ \frac{3\pi}{2} + 2 \right]$

Ans. (2)

Sol.

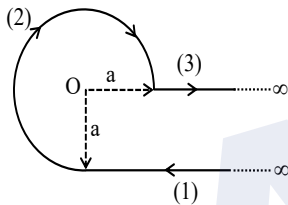

$$B_1 = \frac{\mu_0 i}{4\pi a} \otimes$$

$$B_2 = \frac{\mu_0 i}{4\pi a} \left( \frac{3\pi}{2} \right) \otimes$$

$$B_3 = 0$$

$$B = \frac{\mu_0 i}{4\pi a} \left( 1 + \frac{3\pi}{2} \right) \otimes$$

42. A uniform rod of mass 250 g having length 100 cm is balanced on a sharp edge at 40 cm mark. A mass of 400 g is suspended at 10 cm mark. To maintain the balance of the rod, the mass to be suspended at 90 cm mark, is

- (1) 300 g      (2) 190 g  
(3) 200 g      (4) 290 g

Ans. (2)

Sol.

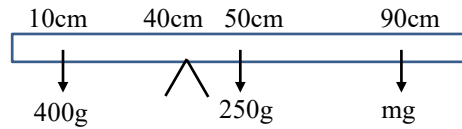

$$\tau_{Net} = 0 \Rightarrow (400g \times 30) = (250g \times 10) + (mg \times 50)$$

$$m = \frac{12000 - 2500}{50} = \frac{9500}{50}$$

$$M = 190 \text{ g}$$

43. a 400 g solid cube having an edge of length 10 cm floats in water. How much volume of the cube is outside the water ?

(Given : density of water =  $1000 \text{ kg m}^{-3}$ )

- (1) 1400  $\text{cm}^3$       (2) 4000  $\text{cm}^3$   
(3) 400  $\text{cm}^3$       (4) 600  $\text{cm}^3$

Ans. (4)

$$\text{Sol. } Mg = F_B \Rightarrow (400 \times 10^{-3}) = 10^3 \times V_d$$

$$V_d = 400 \times 10^{-6} \text{ m}^3$$

$$(\text{Vol.})_{\text{outside}} = (10 \times 10^{-2})^3 - 400 \times 10^{-6}$$

$$= 600 \times 10^{-6} \text{ m}^3 = 600 \text{ cm}^3$$

44. The magnetic field of an E.M. wave is given by

$$\vec{B} = \left( \frac{\sqrt{3}}{2} \hat{i} + \frac{1}{2} \hat{j} \right) 30 \sin \left[ \omega \left( t - \frac{z}{c} \right) \right] \text{ (S.I. Units)}$$

The corresponding electric field in S.I. units is :

(1)  $\vec{E} = \left( \frac{1}{2} \hat{i} - \frac{\sqrt{3}}{2} \hat{j} \right) 30c \sin \left[ \omega \left( t - \frac{z}{c} \right) \right]$

(2)  $\vec{E} = \left( \frac{3}{4} \hat{i} + \frac{1}{4} \hat{j} \right) 30c \cos \left[ \omega \left( t - \frac{z}{c} \right) \right]$

(3)  $\vec{E} = \left( \frac{1}{2} \hat{i} + \frac{\sqrt{3}}{2} \hat{j} \right) 30c \sin \left[ \omega \left( t + \frac{z}{c} \right) \right]$

(4)  $\vec{E} = \left( \frac{\sqrt{3}}{2} \hat{i} - \frac{1}{2} \hat{j} \right) 30c \sin \left[ \omega \left( t + \frac{z}{c} \right) \right]$

Ans. (1)

$$\text{Sol. } \vec{B} = \left( \frac{\sqrt{3}}{2} \hat{i} + \frac{1}{2} \hat{j} \right) 30 \sin \left[ \omega \left( t - \frac{z}{c} \right) \right]$$

$$\vec{E} = \vec{B} \times \vec{c} \text{ and } E = B_0 c$$

$$\text{Here } \vec{E} = \left( \frac{\sqrt{3}}{2} (-\hat{j}) + \frac{1}{2} \hat{i} \right)$$

$$E_0 = 30c$$

$$\vec{E} = \left( \frac{1}{2} \hat{i} - \frac{\sqrt{3}}{2} \hat{j} \right) 30c \sin \left[ \omega \left( t - \frac{z}{c} \right) \right]$$

45. A balloon and its content having mass  $M$  is moving up with an acceleration ' $a$ '. The mass that must be released from the content so that the balloon starts moving up with an acceleration ' $3a$ ' will be : (Take ' $g$ ' as acceleration due to gravity)

- (1)  $\frac{3Ma}{2a - g}$                       (2)  $\frac{3Ma}{2a + g}$   
(3)  $\frac{2Ma}{3a + g}$                       (4)  $\frac{2Ma}{3a - g}$

Ans. (3)

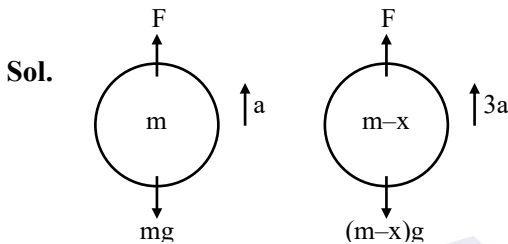

$$F - mg = ma$$

$$F = ma + mg$$

$$F - (m - x)g = (m - x) 3a$$

Put F

$$Ma + mg - mg + xg = 3ma - 3xa$$

$$x = \frac{2ma}{g + 3a}$$

**SECTION-B**

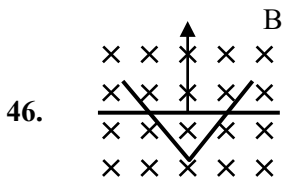

A conducting bar moves on two conducting rails as shown in the figure. A constant magnetic field  $B$  exists into the page. The bar starts to move from the vertex at time  $t = 0$  with a constant velocity. If the induced EMF is  $E \propto t^n$ , then value of  $n$  is \_\_\_\_ .

Ans. (1)

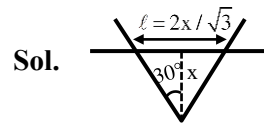

$$E = \ell vB$$

$$E = \frac{2x}{\sqrt{3}} \times vB \text{ and } x = vt$$

$$E = \frac{2}{\sqrt{3}} v^2 Bt \quad E \propto t^1$$

47. An electric dipole of dipole moment  $6 \times 10^{-6} \text{ Cm}$  is placed in uniform electric field of magnitude  $10^6 \text{ V/m}$ . Initially, the dipole moment is parallel to electric field. The work that needs to be done on the dipole to make its dipole moment opposite to the field, will be \_\_\_\_ J.

Ans. (12)

Sol.  $p = 6 \times 10^{-6} \text{ Cm}$

$$E = 10^6 \text{ v/m}$$

$$W = \Delta U = -pE(\cos\theta_f - \cos\theta_i)$$

$$W = 2pE = 12 \text{ J}$$

48. The volume contraction of a solid copper cube of edge length 10 cm, when subjected to a hydraulic pressure of  $7 \times 10^6 \text{ Pa}$ , would be \_\_\_\_  $\text{mm}^3$ .

(Given bulk modulus of copper =  $1.4 \times 10^{11} \text{ Nm}^{-2}$ )

Ans. (50)

Sol.  $B = \frac{\Delta P}{\frac{\Delta V}{V}}$

$$\Delta V = \frac{7 \times 10^6}{1.4 \times 10^{11}} \times (10 \times 10^{-2})^3$$

$$\Delta V = 50 \text{ mm}^3$$

49. The value of current  $I$  in the electrical circuit as given below, when potential at  $A$  is equal to the potential at  $B$ , will be \_\_\_\_\_ A.

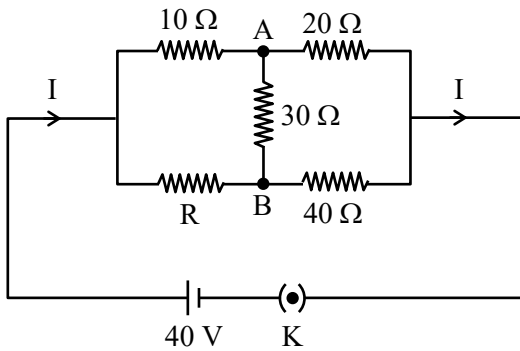

Ans. (2)

Sol.

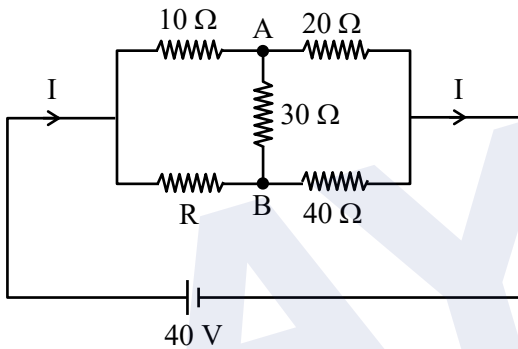

$V_A = V_B \Rightarrow$  the bridge is balanced

$$\Rightarrow \frac{10}{R} = \frac{20}{40}$$

$$R = 20\Omega$$

$$I = \frac{40}{20} = 2A$$

50. A thin transparent film with refractive index 1.4, is held on circular ring of radius 1.8 cm. The fluid in the film evaporates such that transmission through the film at wavelength 560 nm goes to a minimum every 12 seconds. Assuming that the film is flat on its two sides, the rate of evaporation is \_\_\_\_\_  $\pi \times 10^{-13} \text{ m}^3/\text{s}$ .

Ans. (54)

Sol. Maxima condition

$$2\mu t = n\lambda \Rightarrow t = \frac{n\lambda}{2\mu} \Rightarrow t = \frac{\lambda}{2\mu}, \frac{2\lambda}{2\mu}, \dots$$

Minima condition  $2\mu t = (2n - 1)\lambda/2$

$$\Rightarrow t = \frac{(2n - 1)\lambda}{4\mu} \Rightarrow t = \frac{\lambda}{4\mu}, \frac{3\lambda}{4\mu}, \dots$$

$$\Delta t = \frac{2\lambda}{4\mu}$$

$$\text{Rate of evaporation} = \frac{A(\Delta t)}{\text{time}} = 54 \times 10^{-13} \text{ m}^3/\text{s}$$

**JEE-MAIN EXAMINATION – JANUARY 2025**

**(HELD ON TUESDAY 28<sup>th</sup> JANUARY 2025)**

**TIME : 3 : 00 PM TO 6 : 00 PM**

**CHEMISTRY**

**TEST PAPER WITH SOLUTION**

**SECTION-A**

51. consider the elementary reaction

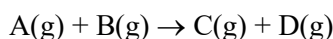

If the volume of reaction mixture is suddenly

reduced to  $\frac{1}{3}$  of its initial volume, the reaction rate

will become 'x' times of the original reaction rate.

The value of x is :

(1)  $\frac{1}{9}$

(2) 9

(3)  $\frac{1}{3}$

(4) 3

Ans. (2)

Sol.  $R_1 = K[A]^{-1} [B]^1$

$$R_1 = K \left[ \frac{n_A}{V} \right]^{-1} \left[ \frac{n_B}{V} \right]^1$$

$$R_2 = K \left[ \frac{3n_A}{V} \right]^{-1} \left[ \frac{3n_B}{V} \right]^1$$

$$R_2 = 9R_1$$

52. The amphoteric oxide among  $V_2O_3$ ,  $V_2O_4$  and  $V_2O_5$  upon reaction with alkali leads to formation of an oxide anion. The oxidation state of V in the oxide anion is :

(1) +3

(2) +7

(3) +5

(4) +4

Ans. (3)

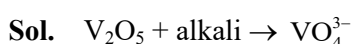

In  $VO_4^{3-}$  ion, vanadium is in +5 oxidation state

53. Match List-I with List-II

**List-I**

(Saccharides)

**List II**

(Glycosidic-linkages found)

(A) Sucrose

(I)  $\alpha$  1 - 4

(B) Maltose

(II)  $\alpha$  1 - 4 and  $\alpha$  1 - 6

(C) Lactose

(III)  $\alpha$  1 -  $\beta$  2

(D) Amylopectin

(IV)  $\beta$  1 - 4

Choose the correct answer from the options given below :

(1) (A)-(III), (B)-(I), (C)-(IV), (D)-(II)

(2) (A)-(IV), (B)-(II), (C)-(I), (D)-(III)

(3) (A)-(II), (B)-(IV), (C)-(III), (D)-(I)

(4) (A)-(I), (B)-(II), (C)-(III), (D)-(IV)

Ans. (1)

Sol. (A) Sucrose  $\rightarrow \alpha_1-\beta_2$  Glycosidic linkage

(B) Maltose  $\rightarrow \alpha$  1-4 Glycosidic linkage

(C) Lactose  $\rightarrow \beta$  1-4 Glycosidic linkage

(D) Amylopectin  $\rightarrow \alpha$  1-4 and  $\alpha$  1-6

Glycosidic linkage

A-III, B-I, C-IV, D-II

54. Identify product [A], [B] and [C] in the following reaction sequence :

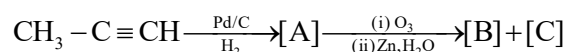

(1) [A] :  $CH_3-CH=CH_2$ , [B] :  $CH_3CHO$ ,  
[C] : HCHO

(2) [A] :  $CH_2=CH_2$ , [B] :  $H_3C-\overset{O}{\parallel}C-CH_3$

[C] : HCHO

(3) [A] :  $CH_3-CH=CH_2$ , [B] :  $CH_3CHO$ ,  
[C] :  $CH_3CH_2OH$

(4) [A] :  $CH_3CH_2CH_3$ , [B] :  $CH_3CHO$ , [C] : HCHO

Ans. (1)

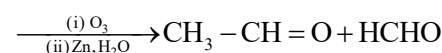
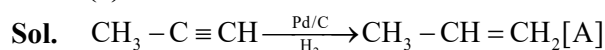

[B]

[C]



59. The product B formed in the following reaction sequence is :

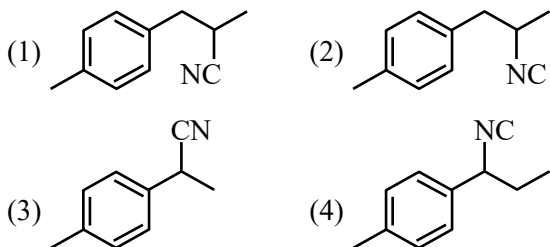
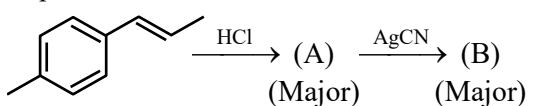

Ans. (4)

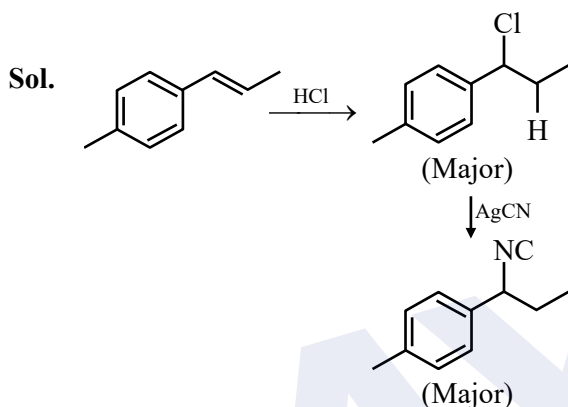

60. Concentrated nitric acid is labelled as 75% by mass. The volume in mL of the solution which contains 30 g of nitric acid is \_\_\_\_\_.

Given : Density of nitric acid solution is 1.25 g/mL

- (1) 45                                      (2) 55  
(3) 32                                      (4) 40

Ans. (3)

Sol. % w/w of  $\text{HNO}_3 = 75\%$

means 100 gm of solution containing 75 g of  $\text{HNO}_3$

$$\& \left( \frac{\text{gm}}{\text{m}_1} \right)_{\text{solution}} = 1.25 = \frac{100 \text{ gm}}{V}$$

$$V_{\text{ml}} \text{ of } 100 \text{ gm solution} = \frac{100}{1.25} \text{ ml}$$

$$\therefore 75 \text{ gm of } \text{HNO}_3 \text{ present in } \frac{100}{1.25} \text{ ml solution}$$

$\therefore$  30 gm of  $\text{HNO}_3$  present in

$$\frac{100}{1.25 \times 75} \times 30 = \boxed{32 \text{ ml solution}}$$

61. Match List-I with List-II.

List-I (Complex)	List-II (Hybridisation of central metal ion)
---------------------	--

- |                                       |                 |
|---------------------------------------|-----------------|
| (A) $[\text{CoF}_6]^{3-}$             | (I) $d^2sp^3$   |
| (B) $[\text{NiCl}_4]^{2-}$            | (II) $sp^3$     |
| (C) $[\text{Co}(\text{NH}_3)_6]^{3+}$ | (III) $sp^3d^2$ |
| (D) $[\text{Ni}(\text{CN})_4]^{2-}$   | (IV) $dsp^2$    |

Choose the **correct** answer from the options given below :

- (1) (A)-(I), (B)-(IV), (C)-(III), (D)-(II)  
(2) (A)-(III), (B)-(II), (C)-(I), (D)-(IV)  
(3) (A)-(I), (B)-(II), (C)-(III), (D)-(IV)  
(4) (A)-(III), (B)-(IV), (C)-(I), (D)-(II)

Ans. (2)

Sol. (A)  $[\text{CoF}_6]^{3-}$

$$\text{Co}^{3+} \rightarrow 3d^6$$

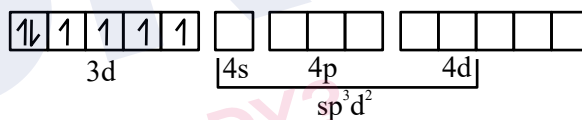

(B)  $[\text{NiCl}_4]^{2-}$

$$\text{Ni}^{2+} \rightarrow 3d^8$$

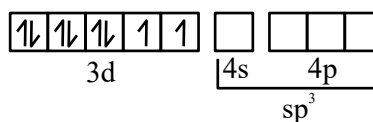

(C)  $[\text{Co}(\text{NH}_3)_6]^{3+}$

$$\text{Co}^{3+} \rightarrow 3d^6$$

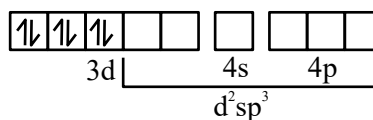

(D)  $[\text{Ni}(\text{CN})_4]^{2-}$

$$\text{Ni}^{2+} \rightarrow 3d^8$$

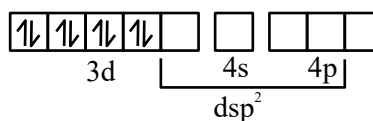

62. The total number of compounds from below when treated with hot  $\text{KMnO}_4$  giving benzoic acid is :

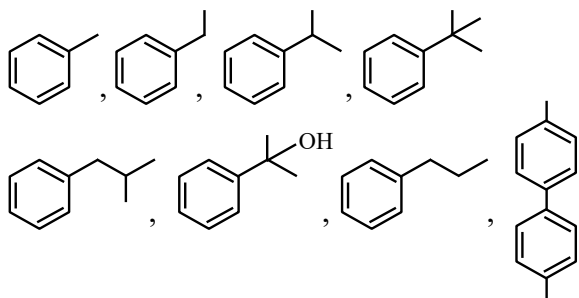

- (1) 3      (2) 4      (3) 6      (4) 5

Ans. (4)

Sol. Compounds having at least 1  $\alpha$ -H will react with  $\text{KMnO}_4$  and give benzoic acid.

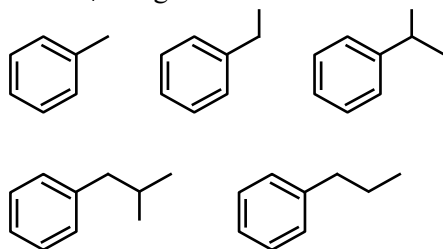

Total 5 compounds

63. The major product of the following reaction is :

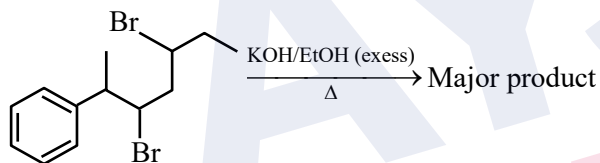

- (1) 6-Phenylhepta-2,4-diene  
(2) 2-Phenylhepta-2,5-diene  
(3) 6-Phenylhepta-3,5-diene  
(4) 2-Phenylhepta-2,4-diene

Ans. (4)

Sol.

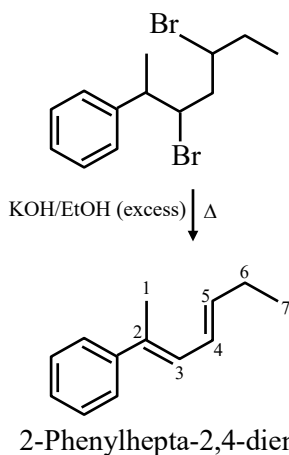

64. Given below are two statements :

**Statement (I) :** According to the Law of Octaves, the elements were arranged in the increasing order of their atomic number.

**Statement (II) :** Meyer observed a periodically repeated pattern upon plotting physical properties of certain elements against their respective atomic numbers.

In the light of the above statements, choose the **correct** answer from the options given below :

- (1) **Statement I** is false but **Statement II** is true  
(2) Both **Statement I** and **Statement II** are true  
(3) **Statement I** is true but **Statement II** is false  
(4) Both **Statement I** and **Statement II** are false

Ans. (4)

Sol. Law of octaves was arranged in the increasing order of their atomic weight.

Lothar Meyer plotted the physical properties such as atomic volume, melting point and boiling point against atomic weight.

65. For bacterial growth in a cell culture, growth law is very similar to the law of radioactive decay. Which of the following graphs is most suitable to represent bacterial colony growth ?

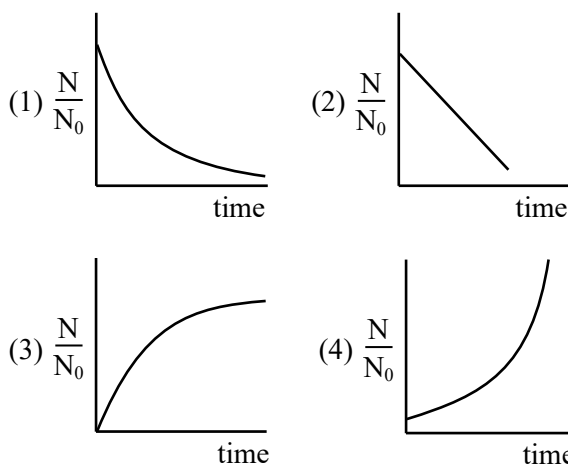

**Ans. (4)**

**Sol.** Because no. of bacteria initial =  $N_0$   
and No. of bacteria at any time  $t = N$   
Since bacterial growth is given as

$$N = N_0 e^{Kt}$$

Where  $K =$  growth constant for bacterial growth

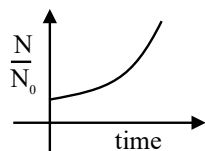

**66.** Which of the following is/are not correct with respect to energy of atomic orbitals of hydrogen atom?

- (A)  $1s < 2p < 3d < 4s$   
(B)  $1s < 2s = 2p < 3s = 3p$   
(C)  $1s < 2s < 2p < 3s < 3p$   
(D)  $1s < 2s < 4s < 3d$

Choose the **correct** answer from the options given below :

- (1) (B) and (D) only      (2) (A) and (C) only  
(3) (C) and (D) only      (4) (A) and (B) only

**Ans. (3)**

**Sol.** For single electron species energy only depends on 'n' (principal quantum number)

So energy of  $2s = 2p$   
and energy of  $3d < 4s$

**67.** Assume a living cell with 0.9% ( $\omega/\omega$ ) of glucose solution (aqueous). This cell is immersed in another solution having equal mole fraction of glucose and water.

(Consider the data upto first decimal place only)

The cell will :

- (1) shrink since solution is 0.5% ( $\omega/\omega$ )  
(2) shrink since solution is 0.45% ( $\omega/\omega$ ) as a result of association of glucose molecules (due to hydrogen bonding)  
(3) swell up since solution is 1% ( $\omega/\omega$ )  
(4) Show no change in volume since solution is 0.9% ( $\omega/\omega$ )

**Ans. (BONUS)**

**NTA (4)**

**Sol.** Living cell = 0.9 gm in 100 gm of solution  
% w/w = 0.9

Solution is have equal moles of glucose and water = 0.5

Weight of solution =  $0.5 \times 180 + 0.5 \times 18 = 99$  gm  
% w/w  $\approx 90\%$

Concentrated solution  
= Cell will shrink.

**68.** Identify correct statements :

- (A) Primary amines do not give diazonium salts when treated with  $\text{NaNO}_2$  in acidic condition.  
(B) Aliphatic and aromatic primary amines on heating with  $\text{CHCl}_3$  and ethanolic KOH form carbylamines.  
(C) Secondary and tertiary amines also give carbylamine test.  
(D) Benzenesulfonyl chloride is known as Hinsberg's reagent.  
(E) Tertiary amines reacts with benzenesulfonyl chloride very easily.

Choose the correct answer from the options given below :

- (1) (B) and (D) only      (2) (A) and (B) only  
(3) (D) and (E) only      (4) (B) and (C) only

**Ans. (1)**

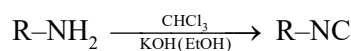
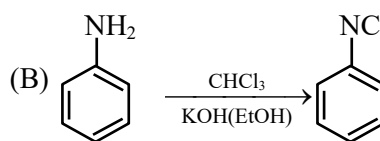

**Sol.** (A)  $\text{R-NH}_2 \xrightarrow[\text{HCl}]{\text{NaNO}_2} \text{R-N}_2^{\oplus}\text{Cl}^{\ominus}$

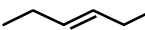

- (C) Only primary amine gives carbyl amine test  
(D)  $\text{Ph-SO}_2\text{Cl} \longrightarrow$  Hinsberg reagent  
Benzene sulphonyl chloride  
(E) Tertiary amine do not react with  $\text{Ph-SO}_2\text{Cl}$   
So correct options are (B) and (D) only

69. Given below are two statements :

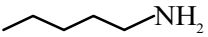
**Statement (I) :**  and  are isomeric compounds.

**Statement (II) :**  and  are functional group isomers.

In the light of the above statements, choose the **correct** answer from the options given below :

- (1) Both **Statement I** and **Statement II** are false
- (2) Both **Statement I** and **Statement II** are true
- (3) **Statement I** is true but **Statement II** is false
- (4) **Statement I** is false but **Statement II** is true

**Ans. (2)**

**Sol. Statement-I** → True

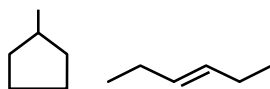

Both are ring chain isomers

**Statement-II** → True

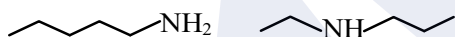

1° Amine

2° Amine

1° Amine and 2° Amine are different functional groups, hence both are functional group isomers.

70. Identify the inorganic sulphides that are yellow in colour :

- |                               |                             |
|-------------------------------|-----------------------------|
| (A) $(\text{NH}_4)_2\text{S}$ | (B) PbS                     |
| (C) CuS                       | (D) $\text{As}_2\text{S}_3$ |
| (E) $\text{As}_2\text{S}_5$   |                             |

Choose the **correct** answer from the options given below :

- |                      |                           |
|----------------------|---------------------------|
| (A) (A) and (C) only | (2) (A), (D) and (E) only |
| (3) (A) and (B) only | (4) (D) and (E) only      |

**Ans. (4)**

**NTA (2)**

**Sol.**  $\text{As}_2\text{S}_3$  and  $\text{As}_2\text{S}_5$  are yellow colour sulphides,  $(\text{NH}_4)_2\text{S}$  is colourless, PbS is black, CuS is black in colour

**SECTION-B**

71. The spin only magnetic moment ( $\mu$ ) value (B.M.) of the compound with strongest oxidising power among  $\text{Mn}_2\text{O}_3$ , TiO and VO is \_\_\_\_\_ B.M. (Nearest integer).

**Ans. (5)**

**Sol.** Strongest oxidising power among the option is  $\text{Mn}_2\text{O}_3$  because of  $E^\circ$  value

$$E^\circ_{\text{Mn}^{+3}/\text{Mn}^{+2}} = +1.57\text{V}$$

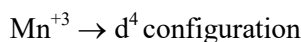

$$\mu = \sqrt{24} \text{ BM}$$

$$= 4.89 \text{ BM}$$

$$\Rightarrow 5$$

72. Consider the following data :

$$\text{Heat of formation of } \text{CO}_2(\text{g}) = -393.5 \text{ kJ mol}^{-1}$$

$$\text{Heat of formation of } \text{H}_2\text{O}(\text{l}) = -286.0 \text{ kJ mol}^{-1}$$

$$\text{Heat of combustion of benzene} = -3267.0 \text{ kJ mol}^{-1}$$

$$\text{The heat of formation of benzene is } \underline{\hspace{2cm}} \text{ kJ mol}^{-1}.$$

(Nearest integer)

**Ans. (48)**

**Sol.**  $\Delta H_f[\text{CO}_2(\text{g})] = -393.5 \text{ kJ / mole}$

$$\Delta H_f[\text{H}_2\text{O}(\ell)] = -286.0 \text{ kJ / mole}$$

$$\Delta H_c[\text{C}_6\text{H}_6] = -3267.0 \text{ kJ / mole}$$

$$\Delta H_f \text{ C}_6\text{H}_6 = (?)$$

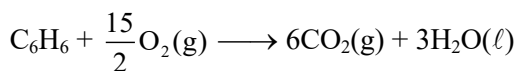

$$\Delta H_R = \Delta H_C = \Sigma \Delta H_f(\text{P}) - \Sigma \Delta H_f(\text{R})$$

$$-3267 = 6 \times (-393.5) + 3(-286) - \Delta H_f(\text{C}_6\text{H}_6)$$

$$\Delta H_f(\text{C}_6\text{H}_6) = 48 \text{ kJ/mole}$$

73. Electrolysis of 600 mL aqueous solution of NaCl for 5 min changes the pH of the solution to 12.

The current in Amperes used for the given electrolysis is \_\_\_\_\_. (Nearest integer).

**Ans. (2)**

**Sol.** Electrolysis of NaCl is

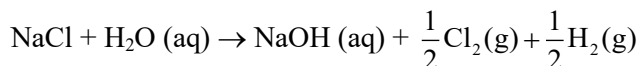

Since during electrolysis pH changes to 12

$$\text{So } [\text{OH}^\ominus] = 10^{-2} \text{ and } [\text{H}^+] = 10^{-12}$$

So by Faraday law

Gram amount of substance deposited =

Amount of electricity passed

$$10^{-2} \times \frac{600}{1000} \times 96500 = I \times t$$

$$\frac{10^{-2} \times 600}{1000} \times 96500 = I \times 5 \times 60$$

$$I = \frac{10^{-2} \times 600 \times 96500}{1000 \times 5 \times 60}$$

$$I = 1.93 \text{ ampere}$$

So, I = 2 ampere (nearest integer)

**74.** A group 15 element forms  $d\pi-d\pi$  bond with transition metals. It also forms hydride, which is a strongest base among the hydrides of other group members that form  $d\pi-d\pi$  bond. The atomic number of the element is \_\_\_\_\_.

**Ans. (15)**

**Sol.** Phosphorus belongs to 15<sup>th</sup> group and forms  $d\pi - d\pi$  bond with transition metal and  $\text{PH}_3$  is strongest base among the other group members except  $\text{NH}_3$ .

**75.** Total number of molecules/species from following which will be paramagnetic is \_\_\_\_\_.

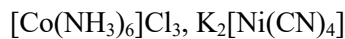

**Ans. (6)**

**Sol.**  $\text{O}_2 \rightarrow 2$  unpaired electrons according to MOT

$\text{O}_2^+ \rightarrow 1$  unpaired electrons according to MOT

$\text{O}_2^- \rightarrow 1$  unpaired electrons according to MOT

$\text{NO} \rightarrow$  odd electron species

$\text{NO}_2 \rightarrow$  odd electron species

$\text{K}_2[\text{NiCl}_4] \rightarrow \text{Ni}^{2+} \Rightarrow 3d^8$  weak Ligand, C.N. = 4

$\Rightarrow$  Tetrahedral, Paramagnetic with 2 unpaired electrons