

**JEE-MAIN EXAMINATION – APRIL 2025**

(HELD ON MONDAY 07<sup>th</sup> APRIL 2025)

TIME : 3:00 PM TO 6:00 PM

**MATHEMATICS**

**TEST PAPER WITH SOLUTION**

**SECTION-A**

1. If the orthocentre of the triangle formed by the lines  $y = x + 1$ ,  $y = 4x - 8$  and  $y = mx + c$  is at  $(3, -1)$ , then  $m - c$  is :

- (1) 0
- (2) -2
- (3) 4
- (4) 2

Ans. (1)

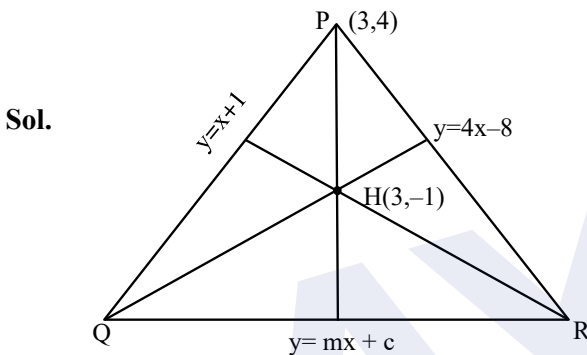

Sol.

Solve line PQ & QR

Point Q  $\left(\frac{1-c}{m-1}, \frac{1-c}{m-1} + 1\right)$

$$m_{2H} = \frac{\frac{1-c}{m-1} + 2}{\frac{1-c}{m-1} - 3} = \frac{1-c + 2m - 2}{1-c - 3m + 3} = -\frac{1}{4} \quad \dots(1)$$

$\therefore m_{PH} = \frac{5}{0} \rightarrow \infty$

$\Rightarrow$  Slope of line QR (m) = 0

Put value of m in equation (1)

$$\frac{1-c-2}{1-c+3} = -\frac{1}{4} \Rightarrow c = 0$$

so  $m - c = 0$  Ans.

2. Let  $\vec{a}$  and  $\vec{b}$  be the vectors of the same magnitude such that  $\frac{|\vec{a} + \vec{b}| + |\vec{a} - \vec{b}|}{|\vec{a} + \vec{b}| - |\vec{a} - \vec{b}|} = \sqrt{2} + 1$ . Then  $\frac{|\vec{a} + \vec{b}|^2}{|\vec{a}|^2}$  is :

- (1)  $2 + 4\sqrt{2}$
- (2)  $1 + \sqrt{2}$
- (3)  $2 + \sqrt{2}$
- (4)  $4 + 2\sqrt{2}$

Ans. (3)

Sol.  $\frac{|\vec{a} + \vec{b}| + |\vec{a} - \vec{b}|}{|\vec{a} + \vec{b}| - |\vec{a} - \vec{b}|} = \sqrt{2} + 1$

Apply componendo and dividendo

$$\Rightarrow \frac{2|\vec{a} + \vec{b}|}{2|\vec{a} - \vec{b}|} = \frac{\sqrt{2} + 2}{\sqrt{2}}$$

$$\Rightarrow |\vec{a} + \vec{b}| = (1 + \sqrt{2})|\vec{a} - \vec{b}|$$

$$\Rightarrow |\vec{a} + \vec{b}|^2 = (3 + 2\sqrt{2})|\vec{a} - \vec{b}|^2$$

$$\Rightarrow 2|\vec{a}|^2 + 2\vec{a} \cdot \vec{b} = (3 + 2\sqrt{2})(2|\vec{a}|^2 - 2\vec{a} \cdot \vec{b})$$

$$\Rightarrow 2|\vec{a}|^2(2 + 2\sqrt{2}) = 2\vec{a} \cdot \vec{b}(4 + 2\sqrt{2})$$

$$\Rightarrow \frac{\vec{a} \cdot \vec{b}}{|\vec{a}|^2} = \frac{2 + 2\sqrt{2}}{4 + 2\sqrt{2}} = \frac{1}{\sqrt{2}}$$

Now

$$\begin{aligned} \frac{|\vec{a} + \vec{b}|^2}{|\vec{a}|^2} &= 1 + \frac{|\vec{b}|^2}{|\vec{a}|^2} + \frac{2\vec{a} \cdot \vec{b}}{|\vec{a}|^2} \\ &= 1 + 1 + 2\left(\frac{1}{\sqrt{2}}\right) = 2 + \sqrt{2} \end{aligned}$$

3. Let  
 $A = \{(\alpha, \beta) \in \mathbf{R} \times \mathbf{R} : |\alpha - 1| \leq 4 \text{ and } |\beta - 5| \leq 6\}$   
 and  
 $B = \{(\alpha, \beta) \in \mathbf{R} \times \mathbf{R} : 16(\alpha - 2)^2 + 9(\beta - 6)^2 \leq 144\}$ .

Then

- (1)  $B \subset A$   
 (2)  $A \cup B = \{(x, y) : -4 \leq x \leq 4, -1 \leq y \leq 11\}$   
 (3) neither  $A \subset B$  nor  $B \subset A$   
 (4)  $A \subset B$

Ans. (1)

Sol.  $A : |x-1| \leq 4 \text{ and } |y-5| \leq 6$   
 $\Rightarrow -4 \leq x-1 \leq 4 \Rightarrow -6 \leq y-5 \leq 6$   
 $\Rightarrow -3 \leq x \leq 5 \Rightarrow -1 \leq y \leq 11$   
 $B : 16(x-2)^2 + 9(y-6)^2 \leq 144$

$$B : \frac{(x-2)^2}{9} + \frac{(y-6)^2}{16} \leq 1$$

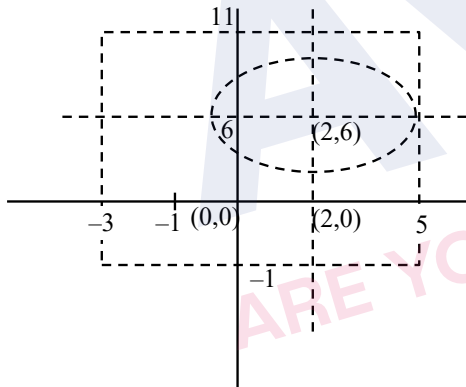

From Diagram  $B \subset A$

4. If the range of the function  $f(x) = \frac{5-x}{x^2-3x+2}$ ,

$x \neq 1, 2$ , is  $(-\infty, \alpha] \cup [\beta, \infty)$ ,

then  $\alpha^2 + \beta^2$  is equal to :

- (1) 190 (2) 192  
 (3) 188 (4) 194

Ans. (4)

Sol.  $y = \frac{5-x}{x^2-3x+2}$   
 $yx^2 - 3xy + 2y + x - 5 = 0$   
 $yz^2 + (-3y+1)x + (2y-5) = 0$

Case I : If  $y = 0$  (Accepted)  
 $\Rightarrow x = 5$

Case II : If  $y \neq 0$

$$D \geq 0$$

$$(-3y+1)^2 - 4(y)(2y-5) \geq 0$$

$$9y^2 + 1 - 6y - 8y^2 + 20y \geq 0$$

$$y^2 + 14y + 1 \geq 0$$

$$(y+7)^2 - 48 \geq 0$$

$$|y+7| \geq 4\sqrt{3}$$

$$\Rightarrow y+7 \geq 4\sqrt{3} \text{ or } y+7 \leq -4\sqrt{3}$$

$$\Rightarrow y \geq 4\sqrt{3}-7 \text{ or } y \leq -4\sqrt{3}-7$$

From Case I and Case II

$$y \in (-\infty, -4\sqrt{3}-7] \cup [4\sqrt{3}-7, \infty)$$

So  $\alpha = -4\sqrt{3}-7$

$\beta = 4\sqrt{3}-7$

$$\Rightarrow a^2 + b^2 = (-4\sqrt{3}-7)^2 + (4\sqrt{3}-7)^2$$

$$= 2(48+49)$$

$$= 194$$

5. A bag contains 19 unbiased coins and one coin with head on both sides. One coin drawn at random is tossed and head turns up. If the probability that the drawn coin was unbiased, is  $\frac{m}{n}$ ,  $\gcd(m, n) = 1$ ,

then  $n^2 - m^2$  is equal to :

- (1) 80 (2) 60  
 (3) 72 (4) 64

Ans. (1)

Sol.  $P(H) = \frac{19}{20} \times \frac{1}{2} + \frac{1}{20} \times 1$  Head occurs

Selection of unbiased
Head occurs
Selection of biased coin

$$\text{Required probability} = \frac{\frac{19}{20} \times \frac{1}{2}}{\frac{19}{20} \times \frac{1}{2} + \frac{1}{20} \times 1} = \frac{19}{21}$$

$$\therefore \frac{m}{n} = \frac{19}{21}$$

$$\Rightarrow n^2 - m^2 = 441 - 361 = 80$$

6. Let a random variable  $X$  take values 0, 1, 2, 3 with  $P(X = 0) = P(X = 1) = p$ ,  $P(X = 2) = P(X = 3) = q$  and  $E(X^2) = 2E(X)$ . Then the value of  $8p - 1$  is :

- (1) 0 (2) 2  
(3) 1 (4) 3

**Ans. (2)**

**Sol.**  $2p + 2q = \frac{1}{2}$

$p + q$

$E(X^2) = \sum_{i=0}^3 x_i^2 p(x_i) = 0 \cdot p + 1 \cdot p + 4 \cdot q + 9q$

$= p + 13q$

$E(x) = \sum_{i=0}^3 x_i p(x_i) = 0 \cdot p + 1 \cdot p + 2q + 3q = p + 5q$

$p + 13q = 2(p + 5q)$

$p = 3q$

So,  $q = \frac{1}{8}$  &  $p = \frac{3}{8}$

So,  $8p - 1 = 2$  **Option (2)**

7. If the area of the region  $\{(x, y) : 1 + x^2 \leq y \leq \min\{x + 7, 11 - 3x\}\}$  is  $A$ , then  $3A$  is equal to

- (1) 50 (2) 49  
(3) 46 (4) 47

**Ans. (1)**

**Sol.**

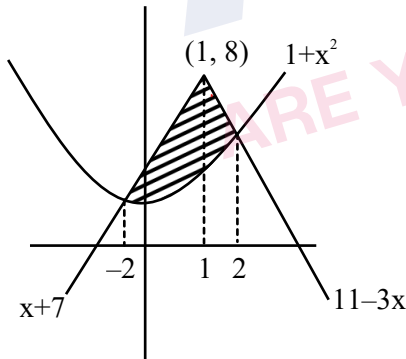

$A = \int_{-2}^1 (x + 7 - x^2 - 1) dx + \int_1^2 (11 + 3x - x^2 - 1) dx$

$= \left[ \frac{x^2}{2} + 6x - \frac{x^3}{3} \right]_{-2}^1 + \left[ 10x - \frac{3x^2}{2} - \frac{x^3}{3} \right]_1^2$

$= \frac{50}{3} \Rightarrow 3A = 50$  **Option (1)**

8. Let  $f : \mathbf{R} \rightarrow \mathbf{R}$  be a polynomial function of degree four having extreme values at  $x = 4$  and  $x = 5$ .

If  $\lim_{x \rightarrow 0} \frac{f(x)}{x^2} = 5$ , then  $f(2)$  is equal to :

- (1) 12 (2) 10  
(3) 8 (4) 14

**Ans. (2)**

**Sol.**  $\lim_{x \rightarrow 0} \frac{f(x)}{x^2} = 5$

$\lim_{x \rightarrow 0} \frac{ax^4 + bx^3 + cx^2 + dx + e}{x^2} = 5$

$c = 5$  and  $d = e = 0$

$f(x) = ax^4 + bx^3 + 5x^2$

$f'(x) = 4ax^3 + 3bx^2 + 10x$

$= x(4ax^2 + 3bx + 10)$

has extremes at 4 and so  $f'(4) = 0$  &  $f'(5) = 0$

so  $a = \frac{1}{8}$  &  $b = \frac{-3}{2}$

so  $f(2) = \frac{1}{8} \times 2^4 - \frac{3}{2} \times 2^3 + 5 \times 2^2$

$= 2 - 12 + 20 = 10$  **Option (2)**

9. The number of solutions of the equation

$\cos 2\theta \cos \frac{\theta}{2} + \cos \frac{5\theta}{2} = 2 \cos^3 \frac{5\theta}{2}$

in  $\left[-\frac{\pi}{2}, \frac{\pi}{2}\right]$  is :

- (1) 7 (2) 5  
(3) 6 (4) 9

**Ans. (1)**

**Sol.**  $\cos 2\theta \cos \frac{\theta}{2} + \cos \frac{5\theta}{2} = 2 \cos^3 \frac{5\theta}{2}$

$$\frac{1}{2} \left( 2 \cos 2\theta \cos \frac{\theta}{2} \right) + \cos \frac{5\theta}{2}$$

$$= \frac{1}{2} \left( \cos \frac{15\theta}{2} + 3 \cos \frac{5\theta}{2} \right)$$

or solving

$$\cos \frac{3\theta}{2} = \cos \frac{15\theta}{2}$$

$$\cos \frac{15\theta}{2} - \cos \frac{3\theta}{2} = 0$$

$$2 \sin 3\theta \sin \frac{9\theta}{2} = 0$$

$$3\theta = n\pi \text{ or } \frac{9\theta}{2} = m\pi$$

$$\theta = \frac{n\pi}{3} \quad \theta = \frac{2m\pi}{9}$$

$$\theta = \left\{ -\frac{\pi}{2}, \frac{\pi}{3}, 0 \right\}$$

$$\theta = \left\{ -\frac{4\pi}{9}, -\frac{2\pi}{9}, \frac{4\pi}{9}, \frac{2\pi}{9} \right\}$$

Option (1)

**10.** Let  $a_n$  be the  $n^{\text{th}}$  term of an A. P.

If  $S_n = a_1 + a_2 + a_3 + \dots + a_n = 700$ ,  $a_6 = 7$  and

$S_7 = 7$ , then  $a_n$  is equal to :

(1) 56

(2) 65

(3) 64

(4) 70

**Ans. (3)**

**Sol.**  $S_n = 700 = \frac{n}{2} [2a + (n-1)d] \dots(i)$

$a_6 = 7 \Rightarrow a + 5d = 7 \dots(ii)$

$S_7 = 7 \Rightarrow \frac{7}{2} (2a + 6d) = 7$

$a + 3d = 1 \dots(iii)$

Solve (ii) and (iii)

$$\frac{n}{2} (-16 + 3n - 3) = 700 \Rightarrow 3n^2 - 19n - 1400 = 0$$

$$(3n + 56)(n - 25) = 0$$

$$\therefore a_{25} = a + 24d = -8 + 24 \times 3$$

$$= -8 + 72$$

$$= 64$$

Ans.  $\rightarrow$  3

**11.** If the locus of  $z \in \mathbb{C}$ , such that

$$\operatorname{Re} \left( \frac{z-1}{2z+i} \right) + \operatorname{Re} \left( \frac{\bar{z}-1}{2\bar{z}-i} \right) = 2,$$

is a circle of radius  $r$  and center  $(a, b)$  then  $\frac{15ab}{r^2}$  is equal to :

(1) 24

(2) 12

(3) 18

(4) 16

**Ans. (3)**

**Sol.**  $\operatorname{Re} \left( \frac{z-1}{2z+i} \right) + \operatorname{Re} \left( \frac{\bar{z}-1}{2\bar{z}-i} \right) = 2$

Here,  $\frac{z-1}{2z+i} = \left( \frac{\bar{z}-1}{2\bar{z}-i} \right) = 2$

$$= \operatorname{Re} \left( \frac{z-1}{2z+i} \right) + \operatorname{Re} \left( \frac{z-1}{2z+i} \right) = 2$$

$$= 2 \operatorname{Re} \left( \frac{z-1}{2z+i} \right) = 2 \Rightarrow \operatorname{Re} \left( \frac{z-1}{2z+i} \right) = 1$$

Let  $z = x + iy$

$$\operatorname{Re} \left( \frac{(x-1)+iy}{2x+i(2y+1)} \right) = 1 \Rightarrow \operatorname{Re} \left[ \frac{((x-1)+iy)(2x-i(2y+1))}{(2x+i(2y+1))(2x-i(2y+1))} \right] = 1$$

$$\Rightarrow \frac{2x(x-1) + y(2y+1)}{4x^2 + (2y+1)^2} = 1$$

$$\Rightarrow 2x^2 - 2x + 2y^2 + y = 4x^2 + 4y^2 + 1 + 4y$$

$$\Rightarrow 2x^2 + 2y^2 + 3y + 2x + 1 = 0$$

$$\Rightarrow x^2 + y^2 + x + \frac{3}{2}y + \frac{1}{2} = 0$$

$$\text{centre} = \left( \frac{-1}{2}, \frac{-3}{4} \right), r = \sqrt{\frac{1}{4} + \frac{9}{16} - \frac{1}{2}} = \frac{\sqrt{5}}{4}$$

$$a = \frac{-1}{2}, b = \frac{-3}{4}, r^2 = \frac{5}{16}$$

$$15 \frac{ab}{r^2} = 15 \times \left( \frac{-1}{2} \right) \times \left( \frac{-3}{4} \right) \times \frac{16}{5} = 18$$

**12.** Let the length of a latus rectum of an ellipse

$$\frac{x^2}{a^2} + \frac{y^2}{b^2} = 1 \text{ be } 10. \text{ If its eccentricity is the}$$

minimum value of the function  $f(t) = t^2 + t + \frac{11}{12}$ ,

$t \in \mathbb{R}$ , then  $a^2 + b^2$  is equal to :

(1) 125

(2) 126

(3) 120

(4) 115

**Ans. (2)**

**Sol.** Length of LR =  $\frac{2b^2}{a} = 10 \Rightarrow \boxed{5a = b^2}$  .....(1)

$$f(t) = t^2 + t + \frac{11}{12}$$

$$\frac{df(t)}{dt} = 2t + 1 = 0 \Rightarrow t = \frac{-1}{2}$$

$$\text{Min value of } f(t) = \left(\frac{-1}{2}\right)^2 + \left(\frac{-1}{2}\right) + \frac{11}{12}$$

$$= \frac{1}{4} - \frac{1}{2} + \frac{11}{12} = \frac{3-6+11}{12} = \frac{8}{12} = \frac{2}{3} = e$$

$$e^2 = \frac{1-b^2}{a^2} \Rightarrow \frac{4}{9} = \frac{1-b^2}{a^2}$$

$$\Rightarrow \frac{b^2}{a^2} = \frac{1-4}{a} = \frac{5}{a} \Rightarrow \boxed{b^2 = \frac{5a^2}{a}}$$
 .....(2)

From (1) & (2)

$$5a = \frac{5a^2}{a} \Rightarrow a = 9, b = \sqrt{45} = 3\sqrt{5}$$

$$\therefore a^2 + b^2 = 81 + 45 = 126$$

**13.** Let  $y = y(x)$  be the solution of the differential equation  $(x^2+1)y' - 2xy = (x^4 + 2x^2 + 1) \cos x$ ,

$y(0) = 1$ . Then  $\int_{-3}^3 y(x) dx$  is :

- (1) 24 (2) 36  
(3) 30 (4) 18

**Ans. (1)**

**Sol.**  $(x^2 + 1) \frac{dy}{dx} - 2xy = (x^4 + 2x^2 + 1) \cos x$

$$\frac{dy}{dx} - \left(\frac{2x}{x^2+1}\right)y = \frac{(x^2+1)^2 \cos x}{x^2+1} = (x^2+1) \cos x$$

(Linear D.E)

$$P = \frac{-2x}{x^2+1}, Q = (x^2+1) \cos x$$

$$I.F = e^{\int P dx} = e^{\int \frac{-2x}{x^2+1} dx} = \frac{1}{x^2+1}$$

$$y \cdot \frac{1}{x^2+1} = \int (x^2+1) \cos x \cdot \frac{1}{x^2+1} dx$$

$$\frac{y}{x^2+1} = \sin x + c \Rightarrow y \cos = 1 \Rightarrow c = 1$$

$$y = (x^2+1)(\sin x + 1)$$

$$\int_{-3}^3 y dx = \int_{-3}^3 (x^2+1)(\sin x + 1) dx$$

$$dx = \int_{-3}^3 x^2 \sin x + x^2 \sin x + 1 dx$$

$$\Rightarrow \int_{-3}^3 x^2 \sin x dx + \int_{-3}^3 x^2 dx + \int_{-3}^3 \sin x dx + \int_{-3}^3 1 dx$$

$$= 0 + 18 + 0 + 6 = 24$$

**14.** If the equation of the line passing through the point  $\left(0, -\frac{1}{2}, 0\right)$  and perpendicular to the lines

$$\vec{r} = \lambda(\hat{i} + \hat{a}\hat{j} + b\hat{k}) \text{ and}$$

$$\vec{r} = (\hat{i} - \hat{j} - 6\hat{k}) + \mu(-b\hat{i} + \hat{a}\hat{j} + 5\hat{k})$$

is  $\frac{x-1}{-2} = \frac{y+4}{d} = \frac{z-c}{-4}$ , then  $a + b + c + d$  is equal to :

- (1) 10 (2) 14  
(3) 13 (4) 12

**Ans. (2)**

**Sol.** Line is  $\perp^r$  to 2 line  $\Rightarrow$  line will be parallel to

$$(\hat{i} + \hat{a}\hat{j} + b\hat{k}) \times (-b\hat{i} + \hat{a}\hat{j} + 5\hat{k})$$

Parallel vector along the required line is

$$\hat{i}(5a-ab) - \hat{j}(b^2+5) + \hat{k}(a+ab)$$

Dr's of required line  $\propto (5a-ab), -(b^2+5), (a+ab)$

Also Dr's of required line  $\propto -2, d, -4$

$$\therefore \frac{5a-ab}{-2} = \frac{-(b^2+5)}{d} = \frac{a+ab}{-4} \text{ .....(1)}$$

Also point  $\left(0, -\frac{1}{2}, 0\right)$  will lie on  $\frac{x-1}{-2} = \frac{y+4}{d} = \frac{z-c}{-4}$

$$\frac{0-1}{-2} = \frac{-\frac{1}{2}+4}{d} = \frac{0-c}{-4} \Rightarrow d = 7, c = 2$$

$$\text{From (1)} \frac{5a-ab}{-2} = \frac{-b^2-5}{7} = \frac{a+ab}{-4}$$

$$\frac{5a-ab}{-2} = \frac{a+ab}{-4}; \frac{-b^2-5}{7} = \frac{a+ab}{-4}$$

$$\begin{array}{l|l} -20a + 4ab = -2a - 2ab & 4b^2 + 20 = 70 + 7ab \\ 18a = 6ab & 36 + 20 = 70 + 21a \\ \boxed{b=3} & 56 = 28a \Rightarrow \boxed{a=2} \end{array}$$

$$a + b + c + d = 2 + 3 + 2 + 7 = 14$$





**20.** If the sum of the second, fourth and sixth terms of a G.P. of positive terms is 21 and the sum of its eighth, tenth and twelfth terms is 15309, then the sum of its first nine terms is :

- (1) 760 (2) 755  
(3) 750 (4) 757

**Ans. (4)**

**Sol.**  $ar + ar^3 + ar^5 = 21$ ,  $ar^7 + ar^9 + ar^{11} = 15309$   
 $\Rightarrow ar(1 + r^2 + r^4) = 21$ ,  $ar^7(1 + r^2 + r^4) = 15309$

\_\_\_\_\_ (1) \_\_\_\_\_ (2)

$\text{Eq}^n(2) \div \text{eq}^n(1)$

$\Rightarrow \frac{a \cdot r^7}{ar} = \frac{15309}{21} \Rightarrow r^6 = 729$

$\Rightarrow \frac{a \cdot (r^9 - 1)}{r - 1} = \frac{7}{91} (19683 - 1) = \frac{7 \times 19682}{91 \times 2}$   
 $= \frac{9841}{13} = 757$

**SECTION-B**

**21.** If the function  $f(x) = \frac{\tan(\tan x) - \sin(\sin x)}{\tan x - \sin x}$  is continuous at  $x = 0$ , then  $f(0)$  is equal to \_\_\_\_\_.

**Ans. (2)**

**Sol.**  $\lim_{x \rightarrow 0} \frac{\frac{\tan(\tan x) - \tan x}{\tan^3 x} + \frac{\tan x - \sin x}{x^3} + \frac{\sin x - \sin(\sin x)}{\sin^3 x}}{\frac{\tan x - \sin x}{x^3}}$   
 $= \frac{\frac{1}{3} + \frac{1}{2} + \frac{1}{6}}{\frac{1}{2}} = 2$

**22.** If  $\int \left( \frac{1}{x} + \frac{1}{x^3} \right) \left( \sqrt[23]{3x^{-24} + x^{-26}} \right) dx$   
 $= \frac{-\alpha}{3(\alpha+1)} (3x^\beta + x^\gamma)^{\frac{\alpha+1}{\alpha}} + C, x > 0$ ,  
 $(\alpha, \beta, \gamma \in \mathbb{Z})$ , where  $C$  is the constant of integration, then  $\alpha + \beta + \gamma$  is equal to \_\_\_\_\_.

**Ans. (19)**

**Sol.**  $\int \left( \frac{1}{x^2} + \frac{1}{x^4} \right) \left( \frac{3}{x} + \frac{1}{x^3} \right)^{\frac{1}{23}} dx$   
using  $t = \frac{3}{x} + \frac{1}{x^3} \Rightarrow dt = -3 \left( \frac{1}{x^2} + \frac{1}{x^4} \right) dx$   
 $\int \frac{t^{1/23} dt}{-3} = \frac{t^{24/23}}{\left( \frac{24}{23} \right) (-3)} + C$   
 $\Rightarrow \alpha = 23, \beta = -1, \gamma = -3$   
 $\alpha + \beta + \gamma = 19$

**23.** For  $t > -1$ , let  $\alpha_t$  and  $\beta_t$  be the roots of the equation  
 $\left( (t+2)^{\frac{1}{7}} - 1 \right) x^2 + \left( (t+2)^{\frac{1}{6}} - 1 \right) x + \left( (t+2)^{\frac{1}{21}} - 1 \right) = 0$ .

If  $\lim_{t \rightarrow -1^+} \alpha_t = a$  and  $\lim_{t \rightarrow -1^+} \beta_t = b$ , then  $72(a+b)^2$  is equal to \_\_\_\_\_.

**Ans. (98)**

**Sol.**  $a + b = \lim_{t \rightarrow -1^+} (\alpha + \beta) = \lim_{t \rightarrow -1^+} - \frac{(t+2)^{\frac{1}{6}} - 1}{(t+2)^{\frac{1}{7}} - 1}$

let  $t + 2 = y$

$a + b = \lim_{y \rightarrow 1^+} \frac{y^{1/6} - 1}{y^{1/7} - 1} = \frac{7}{6}$

$72(a + b)^2 = 72 \cdot \frac{49}{36} = 98$

**24.** Let the lengths of the transverse and conjugate axes of a hyperbola in standard form be  $2a$  and  $2b$ , respectively, and one focus and the corresponding directrix of this hyperbola be  $(-5, 0)$  and  $5x + 9 = 0$ , respectively. If the product of the focal distances of a point  $(\alpha, 2\sqrt{5})$  on the hyperbola is  $p$ , then  $4p$  is equal to \_\_\_\_\_.

**Ans. (189)**

**Sol.**  $PF_1 \cdot PF_2 = (e\alpha - a)(e\alpha + a)$   
 $P = e^2 \alpha^2 - a^2 = \frac{25}{9} \cdot \frac{9}{4} - 9 = \frac{189}{4}$   
 $\left. \begin{aligned} ae = 5 \\ \frac{a}{e} = 9/5 \end{aligned} \right\} \begin{aligned} a = 3 \\ e = 5/3 \\ b = 4 \end{aligned}$   
 $\frac{x^2}{9} - \frac{y^2}{16} = 1$   
 $\frac{\alpha^2}{9} - \frac{4(5)}{16} = 1 \Rightarrow \alpha^2 = 9 \left( \frac{36}{16} \right)$

**25.** The sum of the series  
 $2 \times 1 \times {}^{20}C_4 - 3 \times 2 \times {}^{20}C_5 + 4 \times 3 \times {}^{20}C_6 - 5 \times 4 \times {}^{20}C_7 + \dots + 18 \times 17 \times {}^{20}C_{20}$ , is equal to

**Ans. (34)**

**Sol.**  $(1 - x)^{20} = {}^{20}C_0 - {}^{20}C_1 x + {}^{20}C_2 x^2 - \dots + {}^{20}C_{20} x^{20}$   
 $\frac{(1 - x)^{20}}{x^2} = \frac{{}^{20}C_0}{x^2} - \frac{{}^{20}C_1}{x} + {}^{20}C_2 - {}^{20}C_3 x + {}^{20}C_4 x^2 - \dots$   
Diff twice and put  $x = 1$   
 $= 6 - {}^{20}C_1 (2) + A$   
 $A = 40 - 6 = 34$



**Sol.**  $L = \frac{\mu_0 NA}{\ell}$

$$C = \frac{A \epsilon_0}{d}$$

$$\frac{L}{C} \propto \frac{\mu_0}{\epsilon_0}$$

$$\sqrt{\frac{\mu_0}{\epsilon_0}} \propto \sqrt{\frac{L}{C}}$$

$$\frac{L}{C} = \frac{\tau R}{(\tau/R)} = R^2$$

$$\sqrt{\frac{\mu_0}{\epsilon_0}} = R$$

- 30.** A photo-emissive substance is illuminated with a radiation of wavelength  $\lambda_i$  so that it releases electrons with de-Broglie wavelength  $\lambda_e$ . The longest wavelength of radiation that can emit photoelectron is  $\lambda_0$ . Expression for de-Broglie wavelength is given by :
- (m : mass of the electron, h : Planck's constant and c : speed of light)

$$(1) \lambda_e = \sqrt{\frac{h}{2mc \left( \frac{1}{\lambda_i} - \frac{1}{\lambda_0} \right)}}$$

$$(2) \lambda_e = \sqrt{\frac{h\lambda_0}{2mc}}$$

$$(3) \lambda_e = \frac{h}{\sqrt{2mc \left( \frac{1}{\lambda_i} - \frac{1}{\lambda_0} \right)}}$$

$$(4) \lambda_e = \sqrt{\frac{h\lambda_i}{2mc}}$$

**Ans. (1)**

**Sol.** K.E = E - W

$$\lambda_e = \frac{h}{\sqrt{2mK.E}}, E = \frac{hc}{\lambda_i}, W = \frac{hc}{\lambda_0}$$

$$\frac{h^2}{2m\lambda_e^2} = \frac{hc}{\lambda_i} - \frac{hc}{\lambda_0}$$

$$\lambda_e = \sqrt{\frac{h}{2mc \left( \frac{1}{\lambda_i} - \frac{1}{\lambda_0} \right)}}$$

- 31.** Given below are two statements : one is labelled as **Assertion (A)** and the other is labelled as **Reason (R)**.

**Assertion (A) :** The radius vector from the Sun to a planet sweeps out equal areas in equal intervals of time and thus areal velocity of planet is constant.

**Reason (R) :** For a central force field the angular momentum is a constant.

In the light of the above statements, choose the **most appropriate answer** from the options given below :

- (1) Both (A) and (R) are correct and (R) is the correct explanation of (A)
- (2) Both (A) and (R) are correct but (R) is not the correct explanation of (A)
- (3) (A) is correct but (R) is not correct
- (4) (A) is not correct but (R) is correct

**Ans. (1)**

**Sol.**  $\frac{dA}{dt} = \frac{L}{2m}$

Due to central force torque is zero & angular momentum is constant.

- 32.** The helium and argon are put in the flask at the same room temperature (300 K). The ratio of average kinetic energies (per molecule) of helium and argon is :

(Give : Molar mass of helium = 4 g/mol, Molar mass of argon = 40 g/mol)

- (1) 1 : 10
- (2) 10 : 1
- (3) 1 :  $\sqrt{10}$
- (4) 1 : 1

**Ans. (4)**

**Sol.**  $K.E = \frac{f}{2} KT$

For He and Ar  $f = 3$

$$\frac{K.E_{He}}{K.E_{Ar}} = \frac{1}{1}$$

**33.** A capillary tube of radius 0.1 mm is partly dipped in water (surface tension 70 dyn/cm and glass water contact angle  $\approx 0^\circ$ ) with  $30^\circ$  inclined with vertical. The length of water risen in the capillary is \_\_\_\_\_ cm.

(Take  $g = 9.8 \text{ m/s}^2$ )

- (1)  $\frac{82}{5}$       (2)  $\frac{57}{2}$       (3)  $\frac{71}{5}$       (4)  $\frac{68}{5}$

**Ans. (1)**

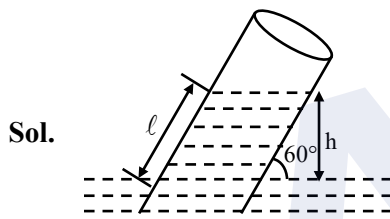

$$h = \frac{2T \cos \theta}{\rho g r} = \frac{2 \times 70 \times 1}{1 \times 980 \times 10^{-2}}$$

$$h = \frac{100}{7} \text{ cm}$$

$$\sin 60^\circ = \frac{h}{l}$$

$$l = \frac{h \times 2}{\sqrt{3}}$$

$$l = \frac{100}{7} \times \frac{2}{\sqrt{3}}$$

$$= \frac{200}{7 \times \sqrt{3}}$$

$$= 16.49 \text{ cm}$$

**34.** A mirror is used to produce an image with magnification of  $\frac{1}{4}$ . If the distance between object and its image is 40 cm, then the focal length of the mirror is \_\_\_\_\_.

- (1) 10 cm                      (2) 12.7 cm  
(3) 10.7 cm                  (4) 15 cm

**Ans. (3)**

**Sol.**  $m = -\frac{v}{u} = -\left(\frac{v}{-u}\right) = \frac{v}{u}$

$$\frac{1}{4} = \frac{v}{u} \Rightarrow u = 4v$$

$$v + u = 40$$

$$5v = 40$$

$$v = 8 \text{ cm}$$

$$u = 32 \text{ cm}$$

$$\frac{1}{v} + \frac{1}{u} = \frac{1}{f}$$

$$\frac{1}{8} - \frac{1}{32} = \frac{1}{f}$$

$$\frac{4-1}{32} = \frac{1}{f}$$

$$f = \frac{32}{3} = 10.7 \text{ cm}$$

**35.** A dipole with two electric charges of  $2 \mu\text{C}$  magnitude each, with separation distance  $0.5 \mu\text{m}$ , is placed between the plates of a capacitor such that its axis is parallel to an electric field established between the plates when a potential difference of 5 V is applied. Separation between the plates is 0.5 mm. If the dipole is rotated by  $30^\circ$  from the axis, it tends to realign in the direction due to a torque. The value of torque is :

- (1)  $5 \times 10^{-9} \text{ Nm}$                       (2)  $5 \times 10^{-3} \text{ Nm}$   
(2)  $2.5 \times 10^{-12} \text{ Nm}$                   (4)  $2.5 \times 10^{-9} \text{ Nm}$

**Ans. (1)**

**Sol.**  $E = \frac{v}{d} = \frac{5}{5 \times 10^{-4}} = 10^4 \text{ V/m}$

$$\tau = PE \sin \theta$$

$$\text{Where } P = qa = 2 \times 10^{-6} \times 5 \times 10^{-7} = 1 \times 10^{-12} \text{ C-m}$$

$$\tau = 1 \times 10^{-12} \times 10^4 \times \frac{1}{2} = 5 \times 10^{-9} \text{ N-m}$$

36. Consider the following logic circuit.

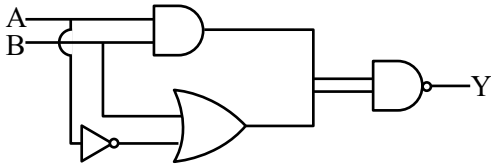

The output is  $Y = 0$  when :

- (1)  $A = 1$  and  $B = 1$       (2)  $A = 0$  and  $B = 1$   
(3)  $A = 1$  and  $B = 0$       (4)  $A = 0$  and  $B = 0$

Ans. (1)

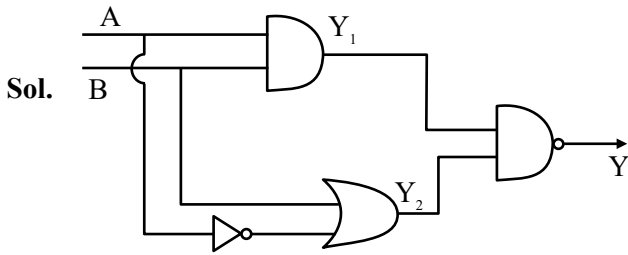

Sol.

$$Y_1 = A \cdot B, Y_2 = \bar{A} + B$$

$$Y = \overline{Y_1 \cdot Y_2} = \bar{Y}_1 + \bar{Y}_2$$

$$Y = \overline{A \cdot B} + \overline{\bar{A} + B}$$

$$Y = \bar{A} + \bar{B} + A \cdot \bar{B}$$

A	B	Y
0	0	1
1	0	1
0	1	1
1	1	0

37. Match List-I with List-II.

List-I		List-II	
(A)	Mass density	(I)	$[ML^2 T^{-3}]$
(B)	Impulse	(II)	$[MLT^{-1}]$
(C)	Power	(III)	$[ML^2 T^0]$
(D)	Moment of inertia	(IV)	$[ML^{-3} T^0]$

Choose the **correct** answer from the options given below :

- (1) (A)-(IV), (B)-(II), (C)-(III), (D)-(I)  
(2) (A)-(I), (B)-(III), (C)-(IV), (D)-(II)  
(3) (A)-(IV), (B)-(II), (C)-(I), (D)-(III)  
(4) (A)-(II), (B)-(III), (C)-(IV), (D)-(I)

Ans. (3)

Sol. (A) Mass density =  $\frac{M}{V} = M^1 L^{-3}$  ... (iv)

(B) Impulse =  $M \times u = M^1 L^1 T^{-1}$  ... (ii)

(C) Power =  $F \cdot V = M^1 L^2 T^{-3}$  ... (i)

(D) Moment of inertia =  $Mr^2 = M^1 L^2$  ... (iii)

38. The equation of a wave travelling on a string is  $y = \sin[20\pi x + 10\pi t]$ , where  $x$  and  $t$  are distance and time in SI units. The minimum distance between two points having the same oscillating speed is :

- (1) 5.0 cm                                      (2) 20 cm  
(3) 10 cm                                      (4) 2.5 cm

Ans. (1)

Sol. Minimum distance between 2 points having same speed is  $\frac{\lambda}{2}$ .

$$\lambda = \frac{2\pi}{k} = \frac{1}{10} \text{ m} = 10 \text{ cm}$$

$$\text{Distance} = \frac{\lambda}{2} = 5 \text{ cm}$$

39. Given below are two statements : one is labelled as **Assertion (A)** and the other is labelled as **Reason (R)**

**Assertion (A)** : Refractive index of glass is higher than that of air.

**Reason (R)** : Optical density of a medium is directly proportionate to its mass density which results in a proportionate refractive index.

In the light of the above statements, choose the **most appropriate answer** from the options given below :

- (1) (A) is not correct but (R) is correct  
(2) Both (A) and (R) are correct and (R) is the correct explanation of (A)  
(3) (A) is correct but (R) is not correct  
(4) Both (A) and (R) are correct but (R) is **not** the correct explanation of (A)

Ans. (3)

Sol. Refractive index has no relation with mass density because both have different meaning. Hence reason is incorrect.

So (A) is correct but (R) is not correct.

40. Given below are two statements : one is labelled as **Assertion (A)** and the other is labelled as **Reason(R)**.

**Assertion (A)** : Magnetic monopoles do not exist.

**Reason (R)** : Magnetic field lines are continuous and form closed loops.

In the light of the above statements, choose the **most appropriate answer** from the options given below :

- (1) Both (A) and (R) are correct but (R) is **not** the correct explanation of (A)
- (2) (A) is correct but (R) is not correct
- (3) Both (A) and (R) are correct and (R) is the correct explanation of (A)
- (4) (A) is not correct but (R) is correct

**Ans. (3)**

**Sol.** Both statements are correct and reason is also the correct explanation of assertion.

41. Which one of the following forces cannot be expressed in terms of potential energy?

- (1) Coulomb's force
- (2) Gravitational force
- (3) Frictional force
- (4) Restoring force

**Ans. (3)**

**Sol.** Potential energy is defined for conservative force only. It is not defined for non-conservative force i.e. frictional force.

42. Match **List-I** with **List-II**.

List-I		List-II	
(A)	Isothermal	(I)	$\Delta W$ (work done) = 0
(B)	Adiabatic	(II)	$\Delta Q$ (supplied heat) = 0
(C)	Isobaric	(III)	$\Delta U$ (change in internal energy) $\neq 0$
(D)	Isochoric	(IV)	$\Delta U = 0$

Choose the **correct** answer from the options given below :

- (1) (A)-(III), (B)-(II), (C)-(I), (D)-(IV)
- (2) (A)-(IV), (B)-(I), (C)-(III), (D)-(II)
- (3) (A)-(IV), (B)-(II), (C)-(III), (D)-(I)
- (4) (A)-(II), (B)-(IV), (C)-(I), (D)-(III)

**Ans. (3)**

- Sol.** (A) Isothermal  $\rightarrow \Delta T = 0 \rightarrow \Delta U = 0$  (IV)  
 (B) Adiabatic  $\rightarrow \Delta Q = 0$  (II)  
 (C) Isobaric  $\rightarrow \Delta P = 0 \rightarrow \Delta U \neq 0$  (III)  
 (D) Isochoric  $\rightarrow \Delta V = 0 \rightarrow \Delta W = 0$  (I)

43. A helicopter flying horizontally with a speed of 360 km/h at an altitude of 2 km, drops an object at an instant. The object hits the ground at a point O, 20 s after it is dropped. Displacement of 'O' from the position of helicopter where the object was released is :

(use acceleration due to gravity  $g = 10 \text{ m/s}^2$  and neglect air resistance)

- (1)  $2\sqrt{5}$  km
- (2) 4 km
- (3) 7.2 km
- (4)  $2\sqrt{2}$  km

**Ans. (4)**

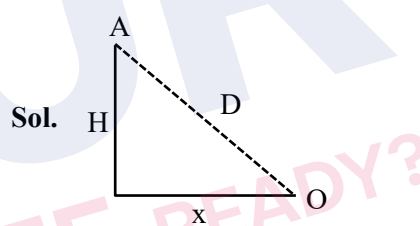

$$u = 360 \times \frac{5}{18} = 100 \text{ m/s}$$

$$x = u \times t = 2 \times 10^3 \text{ m}$$

$$t = \sqrt{\frac{2H}{g}} \Rightarrow H = \frac{t^2 g}{2}$$

$$H = \frac{400 \times 10}{2}$$

$$H = 2000 \text{ m}$$

$$D = \sqrt{x^2 + H^2}$$

$$D = 2\sqrt{2} \text{ km}$$

44. An object with mass 500 g moves along x-axis with speed  $v = 4\sqrt{x}$  m/s. The force acting on the object is :

- (1) 8 N
- (2) 5 N
- (3) 6 N
- (4) 4 N

**Ans. (4)**

**Sol.**  $F = M \times a$

$$v = 4\sqrt{x}$$

$$v^2 = 16x$$

$$2v \frac{dv}{dx} = 16$$

$$\frac{v dv}{dx} = \frac{16}{2} = 8$$

$$F = 0.5 \times 8 = 4 \text{ N}$$

45. A transparent block A having refractive index  $\mu = 1.25$  is surrounded by another medium of refractive index  $\mu = 1.0$  as shown in figure. A light ray is incident on the flat face of the block with incident angle  $\theta$  as shown in figure. What is the maximum value of  $\theta$  for which light suffers total internal reflection at the top surface of the block ?

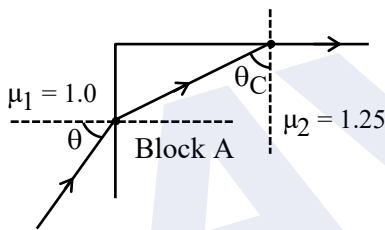

- (1)  $\tan^{-1}(4/3)$                       (2)  $\tan^{-1}(3/4)$   
(3)  $\sin^{-1}(3/4)$                       (4)  $\cos^{-1}(3/4)$

**Ans. (3)**

**Sol.**

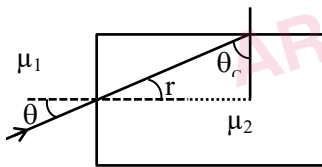

$$r + \theta_c = 90^\circ$$

$$\mu_1 \sin \theta = \mu_2 \sin r$$

$$\sin \theta = \frac{\mu_2}{\mu_1} \sin(90 - \theta_c)$$

$$\sin \theta = \frac{\mu_2}{\mu_1} \cos \theta_c$$

$$\sin \theta_c = \frac{\mu_1}{\mu_2}$$

$$\sin \theta = \frac{\mu_2}{\mu_1} \sqrt{1 - \frac{\mu_1^2}{\mu_2^2}}$$

$$\sin \theta = \sqrt{\frac{\mu_2^2 - \mu_1^2}{\mu_1^2}} = \sqrt{\frac{25}{16} - 1}$$

$$\sin \theta = \frac{3}{4}$$

$$\theta = \sin^{-1}\left(\frac{3}{4}\right)$$

### SECTION-B

46. A parallel plate capacitor has charge  $5 \times 10^{-6} \text{ C}$ . A dielectric slab is inserted between the plates and almost fills the space between the plates. If the induced charge on one face of the slab is  $4 \times 10^{-6} \text{ C}$  then the dielectric constant of the slab is \_\_\_\_\_.

**Ans. (5)**

**Sol.**  $Q_{in} = Q \left(1 - \frac{1}{K}\right)$

$$4 \times 10^{-6} = 5 \times 10^{-6} \left(1 - \frac{1}{K}\right)$$

$$1 - \frac{1}{K} = \frac{4}{5}$$

$$K = 5$$

47. An inductor of reactance  $100 \Omega$ , a capacitor of reactance  $50 \Omega$ , and a resistor of resistance  $50 \Omega$  are connected in series with an AC source of  $10 \text{ V}$ ,  $50 \text{ Hz}$ . Average power dissipated by the circuit is \_\_\_\_\_ W.

**Ans. (1)**

**Sol.**  $P = V_{rms} I_{rms} \cos \phi$

$$P = V_{rms} \times \frac{V_{rms}}{Z} \times \frac{R}{Z}$$

$$P = V_{rms}^2 \times \frac{R}{Z^2}$$

$$Z = \sqrt{R^2 + (X_L - X_C)^2}$$

$$Z = 50\sqrt{2} \Omega$$

$$P = 100 \times \frac{50}{2500 \times 2} = 1 \text{ W}$$

48. Two cylindrical rods A and B made of different materials, are joined in a straight line. The ratio of lengths, radii and thermal conductivities of these rods are :

$$\frac{L_A}{L_B} = \frac{1}{2}, \frac{r_A}{r_B} = 2 \text{ and } \frac{K_A}{K_B} = \frac{1}{2}.$$

The free ends of rods A and B are maintained at 400 K, 200 K, respectively. The temperature of rods interface is \_\_\_\_\_ K, when equilibrium is established.

Ans. (360)

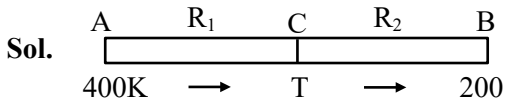

$$R_1 = \frac{\ell_1}{K_1 A_1}, R_2 = \frac{\ell_2}{K_2 A_2}$$

$$\frac{dQ}{dt} = \frac{\Delta T}{R}$$

$$\left(\frac{dQ}{dt}\right)_1 = \left(\frac{dQ}{dt}\right)_2$$

$$\frac{400 - T}{R_1} = \frac{T - 200}{R_2}$$

$$\frac{400 - T}{T - 200} = \frac{R_1}{R_2} = \left(\frac{\ell_1}{\ell_2}\right) \left(\frac{r_2}{r_1}\right)^2 \times \frac{K_2}{K_1}$$

$$= \frac{1}{2} \times \left(\frac{1}{2}\right)^2 \times 2$$

$$= \left(\frac{1}{4}\right)$$

$$\frac{400 - T}{T - 200} = \frac{1}{4}$$

$$1600 - 4T = T - 200$$

$$5T = 1800$$

$$T = 360 \text{ K}$$

49. The electric field in a region is given by  $\vec{E} = (2\hat{i} + 4\hat{j} + 6\hat{k}) \times 10^3 \text{ N/C}$ . The flux of the field through a rectangular surface parallel to x-z plane is  $6.0 \text{ Nm}^2\text{C}^{-1}$ . The area of the surface is \_\_\_\_\_  $\text{cm}^2$ .

Ans. (15)

Sol.  $\phi = \vec{E} \cdot \vec{A} = (2\hat{i} + 4\hat{j} + 6\hat{k}) \times 10^3 \cdot A\hat{j}$

$$6 = 4 \times 10^3 A$$

$$A = 1.5 \times 10^{-3} \text{ m}^2$$

$$= 15 \text{ cm}^2$$

50. M and R be the mass and radius of a disc. A small disc of radius R/3 is removed from the bigger disc as shown in figure. The moment of inertia of remaining part of bigger disc about an axis AB passing through the centre O and perpendicular to the plane of disc is  $\frac{4}{x} MR^2$ . The value of x is \_\_\_\_\_.

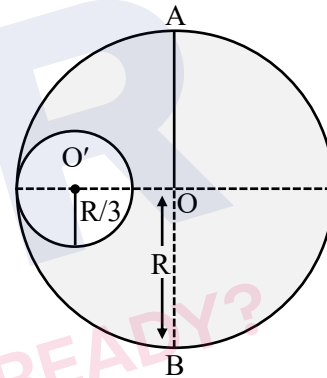

Ans. (9)

Sol. Without cavity  $I_1 = \frac{MR^2}{2}$

$$\text{Mass of removed disc} = \frac{M}{\pi R^2} \times \left(\frac{R}{3}\right)^2 \pi$$

$$= \left(\frac{M}{9}\right)$$

$$\text{M.I. of removed disc } I_2 = \frac{M \left(\frac{R}{3}\right)^2}{2} + \frac{M}{9} \times \left(\frac{2R}{3}\right)^2$$

$$= \frac{MR^2}{18}$$

$$I = I_1 - I_2 = \frac{MR^2}{2} - \frac{MR^2}{18} = \frac{4MR^2}{9}$$

$$(n = 9)$$

**JEE-MAIN EXAMINATION – APRIL 2025**

**(HELD ON MONDAY 07<sup>th</sup> APRIL 2025)**

**TIME : 3:00 PM TO 6:00 PM**

**CHEMISTRY**

**TEST PAPER WITH SOLUTION**

**SECTION-A**

51. Given below are two statements :

**Statement (I) :** On hydrolysis, oligo peptides give rise to fewer number of  $\alpha$ -amino acids while proteins give rise to a large number of  $\beta$ -amino acids.

**Statement (II) :** Natural proteins are denatured by acids which convert the water soluble form of fibrous proteins to their water insoluble form.

In the light of the above statements, choose the **most appropriate answer** from the options given below :

- (1) Both **statement I** and **statement II** are correct
- (2) **Statement I** is incorrect but **Statement II** is correct
- (3) Both **statement I** and **statement II** are incorrect
- (4) **Statement I** is correct but **Statement II** is incorrect

**Ans. (3)**

**Sol.** (i) Protein does not gives  $\beta$ -amino acid on hydrolysis

(ii) Fibrous protein are not water soluble

So both statement's are wrong

52. Mixture of 1 g each of chlorobenzene, aniline and benzoic acid is dissolved in 50 mL ethyl acetate and placed in a separating funnel, 5 M NaOH (30 mL) was added in the same funnel. The funnel was shaken vigorously and then kept aside. The ethyl acetate layer in the funnel contains :

- (1) benzoic acid
- (2) benzoic acid and aniline
- (3) benzoic acid and chlorobenzene
- (4) chlorobenzene and aniline

**Ans. (4)**

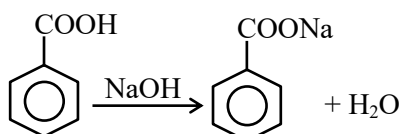
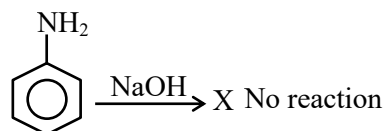
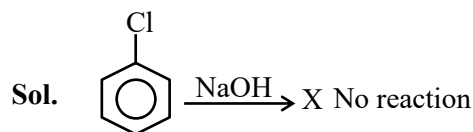

Organic layer in funnel are mixture of chloro benzene and aniline

53. The hydration energies of  $K^+$  and  $Cl^-$  are  $-x$  and  $-y$  kJ/mol respectively. If lattice energy of KCl is  $-z$  kJ/mol, then the heat of solution of KCl is :

- (1)  $+x - y - z$
- (2)  $x + y + z$
- (3)  $z - (x + y)$
- (4)  $-z - (x + y)$

**Ans. (3)**

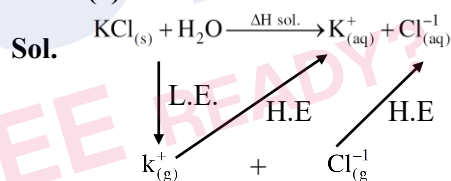

$$\Delta H_{Sol^n} = L.E. + (H.E.)_{K^+_{(g)}} + (H.E.)_{Cl^-_{(g)}}$$

$$= Z - x - y$$

$$= z - (x + y)$$

54.  $A(g) \rightarrow B(g) + C(g)$  is a first order reaction.

<b>Time</b>	T	$\infty$
<b>P<sub>system</sub></b>	$P_t$	$P_\infty$

The reaction was started with reactant A only. Which of the following expression is correct for rate constant k ?

- (1)  $k = \frac{1}{t} \ln \frac{2(p_\infty - P_t)}{P_t}$
- (2)  $k = \frac{1}{t} \ln \frac{P_\infty}{P_t}$
- (3)  $k = \frac{1}{t} \ln \frac{P_\infty}{2(p_\infty - P_t)}$
- (4)  $k = \frac{1}{t} \ln \frac{P_\infty}{(p_\infty - P_t)}$

**Ans. (3)**



**Ans. (3)**

**Sol.** Aromatic halide give nucleophilic substitution reaction at high temperature or in presence of  $-I/-M$  group rate of reaction high even at low temperature.

A-IV

B-III

C-II

D-I

**58.** The correct statement amongst the following is :

(1) The term 'standard state' implies that the temperature is  $0^\circ\text{C}$

(2) The standard state of pure gas is the pure gas at a pressure of 1 bar and temperature 273 K

(3)  $\Delta_f H_{298}^\ominus$  is zero for  $\text{O}(\text{g})$

(4)  $\Delta_f H_{500}^\ominus$  is zero for  $\text{O}_2(\text{g})$

**Ans. (4)**

**Sol.** For standard state  $\Rightarrow$  pressure = 1 bar and temperature is specified only

$$\Rightarrow (\Delta H_f^\ominus)_{\text{O}_2(\text{g})} = 0$$

**59.** Liquid A and B form an ideal solution. The vapour pressure of pure liquids A and B are 350 and 750 mm Hg respectively at the same temperature. If  $x_A$  and  $x_B$  are the mole fraction of A and B in solution while  $y_A$  and  $y_B$  are the mole fraction of A and B in vapour phase then :

(1)  $\frac{x_A}{x_B} < \frac{y_A}{y_B}$

(2)  $\frac{x_A}{x_B} = \frac{y_A}{y_B}$

(3)  $\frac{x_A}{x_B} > \frac{y_A}{y_B}$

(4)  $(x_A - y_A) < (x_B - y_B)$

**Ans. (3)**

**Sol.**  $P_A^\ominus < P_B^\ominus$

$$\frac{P_A^\ominus}{P_B^\ominus} < 1$$

$$\frac{y_A}{y_B} = \frac{P_A^\ominus x_A}{P_B^\ominus x_B}$$

$$\frac{y_A}{y_B} < 1$$

$$\frac{x_A}{x_B}$$

$$\frac{y_A}{y_B} < \frac{x_A}{x_B}$$

**60.** 'X' is the number of acidic oxides among  $\text{VO}_2$ ,  $\text{V}_2\text{O}_3$ ,  $\text{CrO}_3$ ,  $\text{V}_2\text{O}_5$  and  $\text{Mn}_2\text{O}_7$ . The primary valency of cobalt in  $[\text{Co}(\text{H}_2\text{NCH}_2\text{CH}_2\text{NH}_2)_3]_2 (\text{SO}_4)_3$  is Y.

The value of X + Y is :

(1) 5 (2) 4

(3) 2 (4) 3

**Ans. (1)**

**Sol.**  $\text{CrO}_3 = \text{Acidic}$

$\text{Mn}_2\text{O}_7 = \text{Acidic}$

$\therefore x = 2$



$\therefore$  Primary valency = 3

$$\therefore x + y = 5$$

**61.** The descending order of basicity of following amines is :

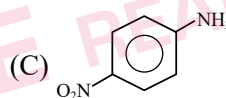
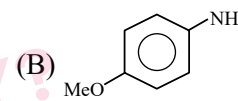
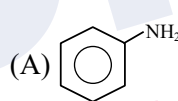

Choose the **correct** answer from the options given below :

(1)  $\text{B} > \text{E} > \text{D} > \text{A} > \text{C}$  (2)  $\text{E} > \text{D} > \text{B} > \text{A} > \text{C}$

(3)  $\text{E} > \text{D} > \text{A} > \text{B} > \text{C}$  (4)  $\text{E} > \text{A} > \text{D} > \text{C} > \text{B}$

**Ans. (2)**

**Sol.** [2]

$\text{E} > \text{D} > \text{B} > \text{A} > \text{C}$

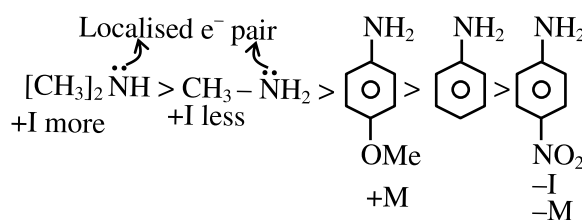

**62. Match List-I with List-II**

List-I Complex		List-II Primary valency and Secondary valency		
(A)	[Co(en) <sub>2</sub> Cl <sub>2</sub> ]Cl	(I)	3	6
(B)	[Pt(NH <sub>3</sub> ) <sub>2</sub> Cl(NO <sub>2</sub> )]	(II)	3	4
(C)	Hg[Co(SCN) <sub>4</sub> ]	(III)	2	6
(D)	[Mg(EDTA)] <sup>2-</sup>	(IV)	2	4

Choose the **correct** answer from the options given below :

- (1) (A)-(III), (B)-(I), (C)-(II), (D)-(IV)  
 (2) (A)-(I), (B)-(IV), (C)-(II), (D)-(III)  
 (3) (A)-(I), (B)-(III), (C)-(II), (D)-(IV)  
 (4) (A)-(II), (B)-(III), (C)-(IV), (D)-(I)

**Ans. (2)**

**Sol.** Primary valency = Oxidation state

Secondary valency = Co-ordination number

	Complex	Primary valency	Secondary
(A)	[Co(en) <sub>2</sub> Cl <sub>2</sub> ]Cl	3	6
(B)	[Pt(NH <sub>3</sub> ) <sub>2</sub> Cl(NO <sub>2</sub> )]	2	4
(C)	Hg[Co(SCN) <sub>4</sub> ]	3	4
(D)	[Mg(EDTA)] <sup>2-</sup>	2	6

**63. Match List-I with List-II**

List-I		List-II	
(A)	Solution of chloroform and acetone	(I)	Minimum boiling azeotrope
(B)	Solution of ethanol and water	(II)	Dimerizes
(C)	Solution of benzene and toluene	(III)	Maximum boiling azeotrope
(D)	Solution of acetic acid in benzene	(IV)	$\Delta V_{\text{mix}} = 0$

Choose the **correct** answer from the options given below :

- (1) (A)-(III), (B)-(I), (C)-(IV), (D)-(II)  
 (2) (A)-(II), (B)-(IV), (C)-(I), (D)-(III)  
 (3) (A)-(III), (B)-(IV), (C)-(I), (D)-(II)  
 (4) (A)-(II), (B)-(I), (C)-(IV), (D)-(III)

**Ans. (1)**

- Sol.** (A) Solution of chloroform and acetone shows -ve deviation, so maximum boiling azeotrope.  
 (B) Solution of ethanol & water shows +ve deviation. So minimum boiling azeotrope.  
 (C) Solution of benzene and toluene form ideal solution.  $\Delta V_{\text{mix}} = 0$ .  
 (D) Acetic acid in benzene form dimer.

**64.** In SO<sub>2</sub>, NO<sub>2</sub><sup>-</sup> and N<sub>3</sub><sup>-</sup> the hybridizations at the central atom are respectively :

- (1) sp<sup>2</sup>, sp<sup>2</sup> and sp                      (2) sp<sup>2</sup>, sp and sp  
 (3) sp<sup>2</sup>, sp<sup>2</sup> and sp<sup>2</sup>                    (4) sp, sp<sup>2</sup> and sp

**Ans. (1)**

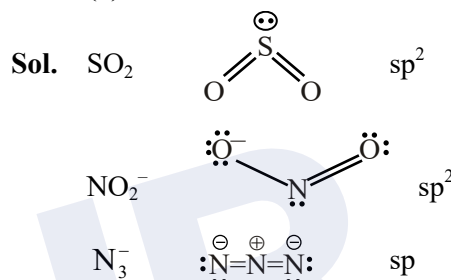

**65.** The number of unpaired electrons responsible for the paramagnetic nature of the following complex species are respectively :

- [Fe(CN)<sub>6</sub>]<sup>3-</sup>, [FeF<sub>6</sub>]<sup>3-</sup>, [CoF<sub>6</sub>]<sup>3-</sup>, [Mn(CN)<sub>6</sub>]<sup>3-</sup>  
 (1) 1, 5, 4, 2                                  (2) 1, 5, 5, 2  
 (3) 1, 1, 4, 2                                  (4) 1, 4, 4, 2

**Ans. (1)**

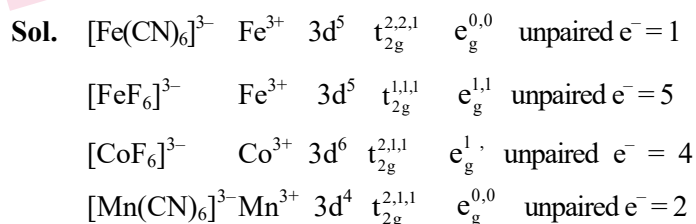

**66.** The number of optically active products obtained from the complete ozonolysis of the given compound is :

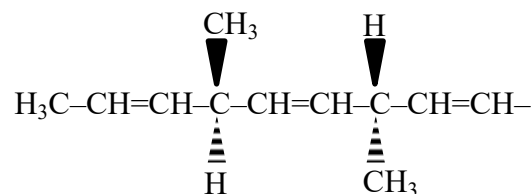

- (1) 2    (2) 0  
 (3) 1    (4) 4

Ans. (2)

Sol.

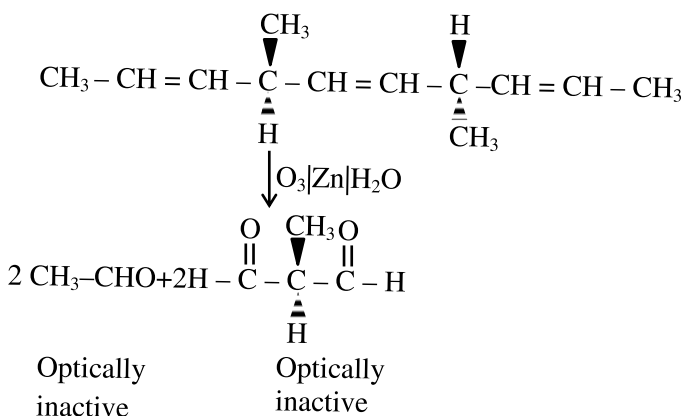

67. Given below are two statements :

Statement (I) :  is more polar than

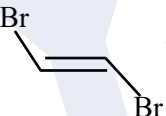

Statement (II) : Boiling point of  is

lower than  but it is more polar than



In the light of the above statements, choose the **most appropriate answer** from the options given below :

- (1) **Statement I** is correct but **statement II** is incorrect
- (2) **Statement I** is incorrect but **statement II** is correct
- (3) Both **statement I** and **statement II** are incorrect
- (4) Both **statement I** and **statement II** are correct

Ans. (1)



Due to vacant -d orbital

more polar

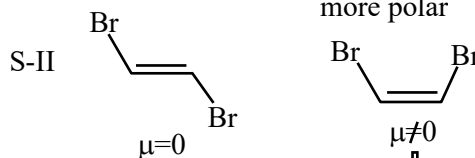

Boiling point higher

68. The extra stability of half-filled subshell is due to
- (A) Symmetrical distribution of electrons
  - (B) Smaller coulombic repulsion energy
  - (C) The presence of electrons with the same spin in non-degenerate orbitals
  - (D) Larger exchange energy
  - (E) Relatively smaller shielding of electrons by one another

Identify the **correct** statements

- (1) (B), (D) and (E) only
- (2) (A), (B), (D) and (E) only
- (3) (B), (C) and (D) only
- (4) (A), (B) and (D) only

Ans. (2)

Sol. Extra stability of half filled is due to :

- (i) Symmetrical distribution of electrons
- (ii) Large exchange energy
- (iii) Smaller coulombic repulsion
- (iv) Smaller shielding of electrons by one another

69. The correct statements from the following are :

- (A)  $\text{Tl}^{3+}$  is a powerful oxidising agent
- (B)  $\text{Al}^{3+}$  does not get reduced easily
- (C) Both  $\text{Al}^{3+}$  and  $\text{Tl}^{3+}$  are very stable in solution
- (D)  $\text{Tl}^+$  is more stable than  $\text{Tl}^{3+}$
- (E)  $\text{Al}^{3+}$  and  $\text{Tl}^+$  are highly stable

Choose the **correct** answer from the options given below :

- (1) (A), (B), (C), (D) and (E)
- (2) (A), (B), (D) and (E) only
- (3) (B), (D) and (E) only
- (4) (A), (C) and (D) only

Ans. (2)

- Sol.** (i) True,  $Tl^+$  is more stable than  $Tl^{3+}$ , due to inert pair effect. So  $Tl^{3+}$  is a powerful oxidising agent.
- (ii) True,  $E_{Al^{3+}/Al}^{\circ} = -1.66V$ . So it is difficult to reduce  $Al^{3+}$ . So  $Al^{3+}$  is highly stable.
- (iii) False, as  $Tl^{3+}$  is unstable
- (iv) True,  $Tl^+$  is more stable than  $Tl^{3+}$
- (v) True,  $Al^{3+}$  and  $Tl^+$  are highly stable

**70.** Given below are two statements :

1 M aqueous solution of each of  $Cu(NO_3)_2$ ,  $AgNO_3$ ,  $Hg_2(NO_3)_2$ ;  $Mg(NO_3)_2$  are electrolysed using inert electrodes,

Given :  $E_{Ag^+/Ag}^{\circ} = 0.80V$ ,  $E_{Hg_2^{2+}/Hg}^{\circ} = 0.79V$ ,

$E_{Cu^{2+}/Cu}^{\circ} = 0.24V$  and  $E_{Mg^{2+}/Mg}^{\circ} = -2.37V$

**Statement (I) :** With increasing voltage, the sequence of deposition of metals on the cathode will be Ag, Hg and Cu

**Statement (II) :** Magnesium will not be deposited at cathode instead oxygen gas will be evolved at the cathode.

In the light of the above statement, choose the **most appropriate answer** from the options given below

- (1) Both **statement I** and **statement II** are incorrect
- (2) **Statement I** is correct but **statement II** is incorrect
- (3) Both **statement I** and **statement II** are correct
- (4) **Statement I** is incorrect but **statement II** is correct

**Ans. (2)**

**Sol. Statement-II**  $\Rightarrow$  At cathode, instead of Mg,  $H_2O(l)$  will reduce & evolve  $H_2$  gas.

**SECTION-B**

**71.** Only litre buffer solution was prepared by adding 0.10 mol each of  $NH_3$  and  $NH_4Cl$  in deionised water. The change in pH on addition of 0.05 mol of HCl to the above solution is  $\times 10^{-2}$ , (Nearest integer) (Given :  $pK_b$  of  $NH_3 = 4.745$  and  $\log_{10}3 = 0.477$ )

**Ans. (48)**

**Sol.**  $pOH = pK_b + \log \frac{[NH_4^+]}{[NH_3]}$

**pOH** = 4.745

on adding 0.05 mole HCl



0.1            0.05            0.1

0.05            0            0.15

$pOH' = 4.745 + \log 3$

$pOH' - pOH = 0.477$

$14 - pH' - 14 + pH = 0.477$

$\Delta pH = 0.477$

$= 47.7 \times 10^{-2} \approx 48 \times 10^{-2}$

**72.** In Dumas' method 292 mg of an organic compound released 50 mL of nitrogen gas ( $N_2$ ) at 300 K temperature and 715 mm Hg pressure. The percentage composition of 'N' in the organic compound is \_\_\_\_\_ % (Nearest integer) (Aqueous tension at 300 K = 15 mm Hg)

**Ans. (18)**

**Sol.** Organic compound  $\xrightarrow{\text{DUMAS}}$   $N_2$   
292 mg

$V = 50$  ml

$P = 715$  mm Hg

$T = 300$  k

Aq. tension = 15 mm Hg

$P_{N_2} = 715 - 15 = 700$  mmHg

$$P_{N_2} = \frac{700}{760} \text{ atm}$$

$$n_{N_2} = \frac{P_{N_2} \cdot V}{RT}$$

$$n_{N_2} = \frac{700}{760} \times \frac{50}{1000} \times \frac{1}{0.0821 \times 300}$$

$$n_N = 2 \times n_{N_2}$$

Mass of N =  $2 \times n_N \times 14$

$$\% N = \frac{\text{mass of N}}{\text{mass of organic compound}} \times 100$$

$$\% N = \frac{700}{760} \times \frac{50}{1000} \times \frac{2 \times 14}{0.0821 \times 300} \times \frac{1000}{292} \times 100$$

$$\% N = 18\%$$

73. Butane reacts with oxygen to produce carbon dioxide and water following the equation given below

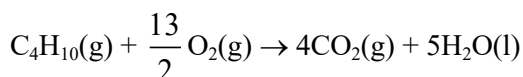

If 174.0 kg of butane is mixed with 320.0 kg of  $O_2$ , the volume of water formed in litres is \_\_\_\_\_. (Nearest integer)

[Given : (a) Molar mass of C, H, O are 12, 1, 16 g mol<sup>-1</sup> respectively, (b) Density of water = 1 g mL<sup>-1</sup>]

Ans. (138)

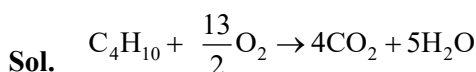

$$3 \times 10^3 \quad 10 \times 10^3$$

$$\text{Moles of } H_2O \text{ formed} = n_{H_2O} = 5 \times \frac{2}{13} \times 10 \times 10^3$$

$$\text{Then } w_{H_2O} = \frac{10^5}{13} \times 18$$

$$= 1.3846 \times 10^5 \text{ g}$$

Volume of  $H_2O$  will be = 138.46 litre.

Ans. 138

74. The number of paramagnetic metal complex species among  $[Co(NH_3)_6]^{3+}$ ,  $[Co(C_2O_4)_3]^{3-}$ ,  $[MnCl_6]^{3-}$ ,  $[Mn(CN)_6]^{3-}$ ,  $[CoF_6]^{3-}$ ,  $[Fe(CN)_6]^{3-}$  and  $[FeF_6]^{3-}$  with same number of unpaired electrons is \_\_\_\_\_.

Ans. (2)



Diamagnetic (unpaired electron = 0)

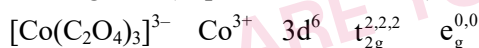

Diamagnetic (unpaired electron = 0)

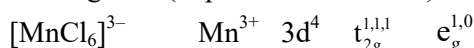

Paramagnetic (unpaired electron = 4)

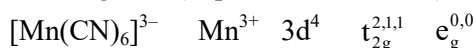

Paramagnetic (unpaired electron = 2)

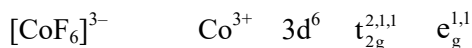

Paramagnetic (unpaired electron = 4)

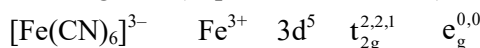

Paramagnetic (unpaired electron = 1)

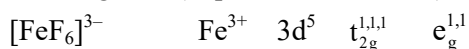

Paramagnetic (unpaired electron = 5)

75. Identify the structure of the final product (D) in the following sequence of the reactions :

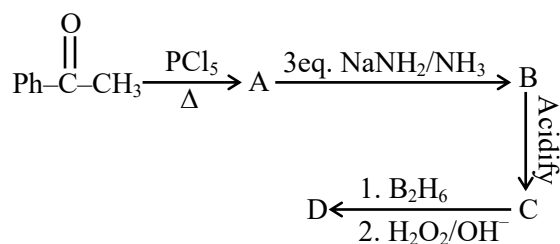

Total number of sp<sup>2</sup> hybridised carbon atoms in product D is.

Ans. (7)

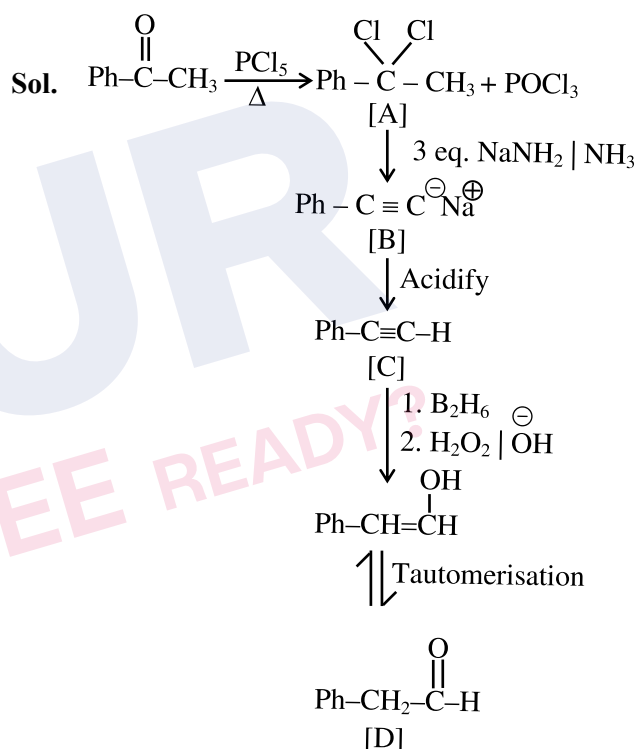

⇒ Number of sp<sup>2</sup> C-atoms in product D = 7

NTA Ans. = 7      ALLEN Ans.=7