

JEE-MAIN EXAMINATION – APRIL 2025

(HELD ON THURSDAY 03rd APRIL 2025)

TIME : 9:00 AM TO 12:00 NOON

MATHEMATICS

TEST PAPER WITH SOLUTION

SECTION-A

1. Let A be a matrix of order 3 x 3 and $|A|=5$. If $|2\text{adj}(3A \text{adj}(2A))|=2^\alpha \cdot 3^\beta \cdot 5^\gamma$, $\alpha, \beta, \gamma \in \mathbb{N}$ then $\alpha + \beta + \gamma$ is equal to

- (1) 25 (2) 26
(3) 27 (4) 28

Ans. (3)

Sol. $|2 \text{adj}(3A \text{adj}(2A))|$

$$2^3 \cdot |3A \text{adj}(2A)|^2$$

$$2^3 \cdot (3^3)^2 \cdot |A|^2 \cdot |\text{adj}(2A)|^2$$

$$2^3 \cdot 3^6 \cdot |A|^2 \cdot (|2A|)^2$$

$$2^3 \cdot 3^6 \cdot |A|^2 \cdot [(2^3)^2 \cdot |A|^2]^2$$

$$2^3 \cdot 3^6 \cdot |A|^2 \cdot 2^{12} \cdot |A|^4$$

$$2^{15} \cdot 3^6 \cdot |A|^6$$

$$2^{15} \cdot 3^6 \cdot 5^6 = 2^\alpha \cdot 3^\beta \cdot 5^\gamma$$

$$\alpha = 15, \beta = 6, \gamma = 6$$

$$\alpha + \beta + \gamma = 27$$

Option (3)

2. Let a line passing through the point (4,1,0) intersect the line $L_1; \frac{x-1}{2} = \frac{y-2}{3} = \frac{z-3}{4}$ at the point A (α, β, γ) and the line $L_2 : x - 6 = y = -z + 4$ at the point B (a, b, c).

Then $\begin{vmatrix} 1 & 0 & 1 \\ \alpha & \beta & \gamma \\ a & b & c \end{vmatrix}$ is equal to

- (1) 8 (2) 16
(3) 12 (4) 6

Ans. (1)

Sol.

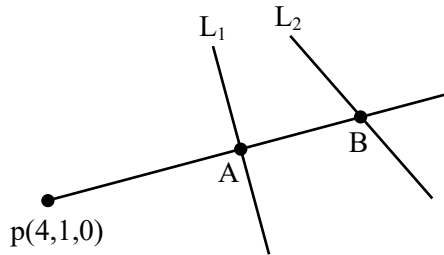

$$L_1 = \frac{x-1}{2} = \frac{y-2}{3} = \frac{z-3}{4} = p$$

$$L_2 = \frac{x-6}{1} = \frac{y}{1} = \frac{z-4}{-1} = q$$

$$A(2p + 1, 3p + 2, 4p + 3)$$

$$B(q + 6, q, 4 - q)$$

$$\text{D.R. of PA} = 2p - 3, 3p + 1, 4p + 3$$

$$\text{D.R. of PB} = q + 2, q - 1, 4 - q$$

$$\frac{2p-3}{q+2} = \frac{3p+1}{q-1} = \frac{4p+3}{4-q}$$

$$2pq - 2p - 3q + 3 = 3pq + 6p + q + 2$$

$$pq + rp + 4q - 1 = 0 \dots(1)$$

$$12p - 3pq + 4 - q = 4pq + 3q - 4p - 3$$

$$7pq - 16p + 4q - 7 = 0 \dots(2)$$

$$8p - 2pq - 12 + 3q = 4pq + 8p + 3q + 6$$

$$6pq = -18 \therefore \boxed{pq = -3}$$

$$8p + 4q = 4 \Rightarrow 2p + q = 1$$

$$-21 - 16p + 4q - 7 \Rightarrow 4p - q = -7$$

$$16p - 4q = -28 \therefore p = -1, q = 3$$

$$A(-1, -1, -1) \quad B(9, 3, 1)$$

$$\begin{vmatrix} 1 & 0 & 1 \\ -1 & -1 & -1 \\ 9 & 3 & 1 \end{vmatrix} = \begin{vmatrix} 0 & -1 & 0 \\ -1 & -1 & -1 \\ 9 & 3 & 1 \end{vmatrix} = 1(-1+9) = 8$$

Option (1)

3. Let α and β be the roots of $x^2 + \sqrt{3}x - 16 = 0$, and γ and δ be the roots of $x^2 + 3x - 1 = 0$. If $P_n = \alpha^n + \beta^n$ and $Q_n = \gamma^n + \delta^n$, then

$$\frac{P_{25} + \sqrt{3}P_{24}}{2P_{23}} + \frac{Q_{25} - Q_{23}}{Q_{24}}$$
 is equal to

- (1) 3 (2) 4
(3) 5 (4) 7

Ans. (3)

Sol. $x^2 + \sqrt{3}x - 16 = 0 \begin{cases} \alpha \\ \beta \end{cases} P_n = \alpha^n + \beta^n$

$$P_n + \sqrt{3}P_{n-1} - 16P_{n-2} = 0$$

$$P_{25} + \sqrt{3}P_{24} - 16P_{23} = 0$$

$$\therefore \frac{P_{25} + \sqrt{3}P_{24}}{2P_{23}} = 8$$

Similarly

$$x^2 + 3x - 1 = 0 \begin{cases} \gamma \\ \delta \end{cases} Q_n = \gamma^n + \delta^n$$

$$\begin{aligned} Q_{25} - Q_{23} &= \gamma^{25} + \delta^{25} - \gamma^{23} - \delta^{23} \\ &= \gamma^{23}(\gamma^2 - 1) + \delta^{23}(\delta^2 - 1) \\ &= \gamma^{23}(-3\gamma) + \delta^{23}(-3\delta) \\ &= -3[\gamma^{24} + \delta^{24}] \\ &= -3 Q_{24} \end{aligned}$$

$$\therefore \frac{Q_{25} - Q_{23}}{Q_{24}} = -3$$

$$\frac{P_{25} + \sqrt{3}P_{24}}{2P_{23}} + \frac{Q_{25} - Q_{23}}{Q_{24}} = 8 - 3 = 5$$

Option (3)

4. The sum of all rational terms in the expansion of

$$(2 + \sqrt{3})^8$$
 is

- (1) 16923 (2) 3763
(3) 33845 (4) 18817

Ans. (4)

Sol. $S = (2 + \sqrt{3})^8$

For sum of rational terms

$$\begin{aligned} &= {}^8C_0(2)^8 + {}^8C_2(2)^6 \cdot (\sqrt{3})^2 + {}^8C_4(2)^4 (\sqrt{3})^4 \\ &\quad + {}^8C_6(2)^2 (\sqrt{3})^6 + {}^8C_8(\sqrt{3})^8 \\ &= 2^8 + 28 \times 2^6 \cdot 3 + 70 \cdot 2^4 \cdot 9 + 28 \cdot 2^2 \cdot 27 + 81 \\ &= 256 + 5376 + 10080 + 3024 + 81 \\ &= 18817 \end{aligned}$$

Option (4)

5. Let $A = \{-3, -2, -1, 0, 1, 2, 3\}$. Let R be a relation on A defined by xRy if and only if $0 \leq x^2 + 2y \leq 4$. Let l be the number of elements in R and m be the minimum number of elements required to be added in R to make it a reflexive relation. then $l + m$ is equal to

- (1) 19 (2) 20
(3) 17 (4) 18

Ans. (4)

Sol. $A = \{-3, -2, -1, 0, 1, 2, 3\}$

$$-2y \leq x^2 \leq 4 - 2y$$

$$y = -3 \quad 6 \leq x^2 \leq 10 \Rightarrow x \in \{-3, 3\}$$

$$y = -2 \quad 4 \leq x^2 \leq 8 \Rightarrow x \in \{-2, 2\}$$

$$y = -1 \quad 2 \leq x^2 \leq 6 \Rightarrow x \in \{-2, 2\}$$

$$y = 0 \quad 0 \leq x^2 \leq 4 \Rightarrow x \in \{-2, -1, 0, 1, 2\}$$

$$y = 1 \quad -2 \leq x^2 \leq 2 \Rightarrow x \in \{-1, 0, 1\}$$

$$y = 2 \quad -4 \leq x^2 \leq 0 \Rightarrow x \in \{0\}$$

$$y = 3 \quad -6 \leq x^2 \leq -2 \Rightarrow \text{No } x\text{-Exist}$$

$$R = \{(-3, -3) (-3, 3), (-2, -2) (-2, 2) (-1, -2) (-1, 2) (0, -2) (0, -1) (0, 0) (0, 1) (0, 2) (1, -1) (1, 0) (1, 1) (2, 0)\}$$

$$\therefore l = 15$$

To make it reflexive we will add

$$\{(-1, -1), (2, 2), (3, 3)\} \therefore m = 3$$

$$\therefore l + m = 15 + 3 = 18$$

Option (4)

6. A line passing through the point $P(\sqrt{5}, \sqrt{5})$ intersects the ellipse $\frac{x^2}{36} + \frac{y^2}{25} = 1$ at A and B such that $(PA) \cdot (PB)$ is maximum. Then $5(PA^2 + PB^2)$ is equal to :

- (1) 218 (2) 377
(3) 290 (4) 338

Ans. (4)

Sol. Given ellipse is $\frac{x^2}{36} + \frac{y^2}{25} = 1$

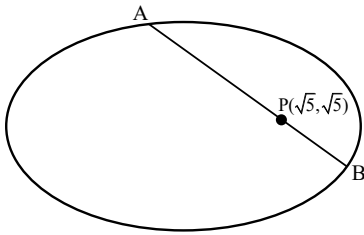

Any point on line AB can be assumed as

$$Q(\sqrt{5} + r \cos \theta, \sqrt{5} + r \sin \theta)$$

Putting this in equation of ellipse, we get

$$25(\sqrt{5} + r \cos \theta)^2 + 36(\sqrt{5} + r \sin \theta)^2 = 900$$

Simplifying, we get

$$r^2(25 \cos^2 \theta + 36 \sin^2 \theta) + 2\sqrt{5}r(25 \cos \theta + 36 \sin \theta) - 595 = 0$$

$$|r| = PA, PB$$

$$\text{Thus, } PA \cdot PB = \frac{595}{25 \cos^2 \theta + 36 \sin^2 \theta} = \frac{595}{25 + 11 \sin^2 \theta}$$

= maximum, if $\sin^2 \theta = 0$

This means line AB must be parallel to x-axis

$$\Rightarrow y_A = y_B = \sqrt{5}$$

Putting $y = \sqrt{5}$ in equation of ellipse, we get

$$\frac{x^2}{36} + \frac{1}{5} = 1 \Rightarrow x^2 = 36 \cdot \frac{4}{5}$$

Hence,

$$PA^2 + PB^2 = \left(\sqrt{5} - \frac{12}{\sqrt{5}}\right)^2 + \left(\sqrt{5} + \frac{12}{\sqrt{5}}\right)^2$$

$$= 2\left(5 + \frac{144}{5}\right) = \frac{338}{5}$$

$$5(PA^2 + PB^2) = 338$$

7. The sum $1 + 3 + 11 + 25 + 45 + 71 + \dots$ upto 20 terms, is equal to

- (1) 7240 (2) 7130
(3) 6982 (4) 8124

Ans. (1)

Sol. Given sum is

$$S_n = 1 + 3 + 11 + 25 + 45 + 71 + \dots + T_n$$

First order differences are in A.P.

Thus, we can assume that

$$T_n = an^2 + bn + c$$

$$\text{Solving } \begin{cases} T_1 = 1 = a + b + c \\ T_2 = 3 = 4a + 2b + c \\ T_3 = 11 = 9a + 3b + c \end{cases},$$

we get $a = 3, b = -7, c = 5$

Hence, general term of given series is

$$T_n = 3n^2 - 7n + 5$$

Hence, required sum equals

$$\sum_{n=1}^{n=20} (3n^2 - 7n + 5) = 3\left(\frac{20 \cdot 21 \cdot 41}{6}\right) - 7\left(\frac{20 \cdot 21}{2}\right) + 5(20) = 7240$$

8. If the domain of the function

$$f(x) = \log_e \left(\frac{2x-3}{5+4x}\right) + \sin^{-1} \left(\frac{4+3x}{2-x}\right) \text{ is } [\alpha, \beta],$$

then $\alpha^2 + 4\beta$ is equal to

- (1) 5 (2) 4
(3) 3 (4) 7

Ans. (2)

Sol. Given function is

$$f(x) = \log_e \left(\frac{2x-3}{5+4x}\right) + \sin^{-1} \left(\frac{4+3x}{2-x}\right)$$

For domain, the conditions are

$$\frac{2x-3}{5+4x} > 0 \text{ and } \left|\frac{4+3x}{2-x}\right| \leq 1$$

$$\text{Now, } \frac{2x-3}{5+4x} > 0 \Rightarrow x \in \left(-\infty, -\frac{5}{4}\right) \cup \left[\frac{3}{2}, \infty\right)$$

$$\text{and } -1 \leq \frac{4+3x}{2-x} \leq 1$$

$$\Rightarrow \left(-1 \leq \frac{4+3x}{2-x}\right) \cap \left(\frac{4+3x}{2-x} \leq 1\right)$$

$$\Rightarrow \left(\frac{6+2x}{2-x} \geq 0\right) \cap \left(\frac{2+4x}{2-x} \leq 0\right)$$

$$\Rightarrow \frac{6+2x}{2-x} \cdot \frac{2+4x}{2-x} \leq 0$$

$$\Rightarrow x \in \left[-3, -\frac{1}{2}\right]$$

Hence, we get the domain of f as $x \in \left[-3, -\frac{5}{4}\right)$

This means that $\alpha = -3, \beta = -\frac{5}{4}$

Thus, $\alpha^2 + 4\beta = 9 - 5 = 4$

9. If $\sum_{r=1}^9 \left(\frac{r+3}{2^r}\right) \cdot {}^9C_r = \alpha \left(\frac{3}{2}\right)^9 - \beta, \alpha, \beta \in \mathbb{N}$, then

$(\alpha + \beta)^2$ is equal to

- (1) 27 (2) 9
(3) 81 (4) 18

Ans. (3)

Sol. Given that

$$\sum_{r=1}^9 \left(\frac{r+3}{2^r}\right) \cdot {}^9C_r = \alpha \left(\frac{3}{2}\right)^9 - \beta, \alpha, \beta \in \mathbb{N}$$

Now,

$$\sum_{r=1}^9 \left(\frac{r+3}{2^r}\right) \cdot {}^9C_r = \sum_{r=1}^9 \left(\frac{r}{2^r}\right) \cdot {}^9C_r + \sum_{r=1}^9 \left(\frac{3}{2^r}\right) \cdot {}^9C_r$$

$$= \sum_{r=1}^9 \left(\frac{9}{2^r}\right) \cdot {}^8C_{r-1} + 3 \sum_{r=1}^9 {}^9C_r \left(\frac{1}{2}\right)^r \left[\text{Using } \frac{{}^9C_r}{8{}^8C_{r-1}} = \frac{9}{r} \right]$$

$$= \frac{9}{2} \sum_{r=1}^9 {}^8C_{r-1} \left(\frac{1}{2}\right)^{r-1} + 3 \left(\sum_{r=0}^9 \left({}^9C_r \left(\frac{1}{2}\right)^r\right) - 1 \right)$$

$$= \frac{9}{2} \left(1 + \frac{1}{2}\right)^8 + 3 \left(\left(1 + \frac{1}{2}\right)^9 - 1 \right)$$

$$= \frac{9}{2} \cdot \left(\frac{3}{2}\right)^8 + 3 \left(\frac{3}{2}\right)^9 - 3 = 6 \cdot \left(\frac{3}{2}\right)^9 - 3$$

Hence, $\alpha = 6, \beta = 3$

Thus $(\alpha + \beta)^2 = 81$

10. The number of solutions of the equation

$$2x + 3\tan x = \pi, x \in [-2\pi, 2\pi] - \left\{ \pm \frac{\pi}{2}, \pm \frac{3\pi}{2} \right\}$$

- (1) 6 (2) 5
(3) 4 (4) 3

Ans. (2)

Sol. $\tan x = \frac{\pi}{3} - \frac{2x}{3}$

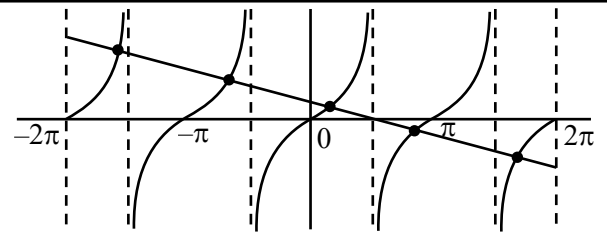

5 solutions

11. If $y(x) = \begin{vmatrix} \sin x & \cos x & \sin x + \cos x + 1 \\ 27 & 28 & 27 \\ 1 & 1 & 1 \end{vmatrix}, x \in \mathbb{R}$,

then $\frac{d^2y}{dx^2} + y$ is equal to

- (1) -1 (2) 28
(3) 27 (4) 1

Ans. (1)

Sol. $C_3 \rightarrow C_3 - C_1$

$$y(x) = \begin{vmatrix} \sin x & \cos x & 1 + \cos x \\ 27 & 28 & 0 \\ 1 & 1 & 0 \end{vmatrix}$$

$$y(x) = -(1 + \cos x)$$

$$\frac{dy}{dx} = \sin x$$

$$\frac{d^2y}{dx^2} = \cos x$$

$$\frac{d^2y}{dx^2} + y = -1$$

12. Let g be a differentiable function such that

$$\int_0^x g(t) dt = x - \int_0^x t g(t) dt, x \geq 0$$
 and let $y = y(x)$

satisfy the differential equation $\frac{dy}{dx} - y \tan x =$

$$2(x+1) \sec x g(x), x \in \left[0, \frac{\pi}{2}\right].$$
 If $y(0) = 0$, then

$y\left(\frac{\pi}{3}\right)$ is equal to

- (1) $\frac{2\pi}{3\sqrt{3}}$ (2) $\frac{4\pi}{3}$
(3) $\frac{2\pi}{3}$ (4) $\frac{4\pi}{3\sqrt{3}}$

Ans. (2)

Sol. Diff. w.r.t. x

$$g(x) = 1 - xg(x)$$

$$g(x) = \frac{1}{1+x}$$

$$\text{so } \frac{dy}{dx} - y \tan x = 2 \sec x$$

$$\text{IF} = e^{-\int \tan x dx} = e^{\log \cos x} = \cos x$$

solution of D.E.

$$y \cos x = \int 2 dx + c$$

$$y \cos x = 2x + c$$

$$y(0) = 0$$

$$\boxed{c = 0}$$

$$y = \frac{2x}{\cos x}$$

$$y = 2x \sec x$$

$$\boxed{y\left(\frac{\pi}{3}\right) = 2 \cdot \frac{\pi}{3} \cdot 2 = \frac{4\pi}{3}}$$

13. A line passes through the origin and makes equal angles with the positive coordinate axes. It intersects the lines

$$L_1 : 2x + y + 6 = 0 \text{ and } L_2 : 4x + 2y - p = 0, p > 0,$$

at the points A and B, respectively. If $AB = \frac{9}{\sqrt{2}}$

and the foot of the perpendicular from the point A on the line L_2 is M, then $\frac{AM}{BM}$ is equal to

(1) 5

(2) 4

(3) 2

(4) 3

Ans. (4)

Sol.

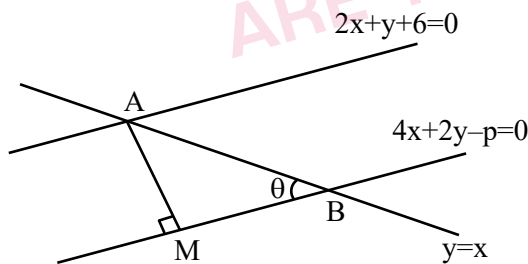

Line is $y = x$

$$m_1 = 1, m_2 = -2$$

$$\text{so } \tan \theta = \left| \frac{1+2}{1-2} \right|$$

$$\boxed{\tan \theta = \frac{AM}{BM} = 3}$$

14. Let $z \in \mathbb{C}$ be such that $\frac{z^2 + 3i}{z - 2 + i} = 2 + 3i$. Then the

sum of all possible values of z^2 is

(1) $19 - 2i$

(2) $-19 - 2i$

(3) $19 + 2i$

(4) $-19 + 2i$

Ans. (2)

Sol. $z^2 + 3i = z(2 + 3i) - 7 - 4i$

$$z^2 - z(2 + 3i) + 7 + 7i = 0 \begin{cases} z_1 \\ z_2 \end{cases}$$

$$z_1^2 + z_2^2 = (z_1 + z_2)^2 - 2z_1z_2$$

$$= 4 - 9 + 12i - 14 - 14i$$

$$= -19 - 2i$$

15. Let $f(x) = \int x^3 \sqrt{3-x^2} dx$. If $5f(\sqrt{2}) = -4$, then

$f(1)$ is equal to

(1) $-\frac{2\sqrt{2}}{5}$

(2) $-\frac{8\sqrt{2}}{5}$

(3) $-\frac{4\sqrt{2}}{5}$

(4) $-\frac{6\sqrt{2}}{5}$

Ans. (4)

Sol. Let $3 - x^2 = t^2$

$$+x dx = -t dt$$

$$f(x) = \int (3 - t^2) \cdot t(-t dt) + c$$

$$= \int (t^4 - 3t^2) dt + c$$

$$= \frac{t^5}{5} - t^3 + c$$

$$f(x) = \frac{(3 - x^2)^{5/2}}{5} - (3 - x^2)^{3/2} + c$$

$$f(\sqrt{2}) = \frac{1}{5} - 1 + c = -\frac{4}{5}$$

$$\boxed{c = 0}$$

$$f(1) = \frac{2^{5/2}}{5} - 2^{3/2}$$

$$= 2^{1/2} \left(\frac{4}{5} - 2 \right)$$

$$\boxed{f(1) = -\frac{6\sqrt{2}}{5}}$$

16. Let a_1, a_2, a_3, \dots be a G. P. of increasing positive numbers. If $a_3 a_5 = 729$ and $a_2 + a_4 = \frac{111}{4}$, then

$24(a_1 + a_2 + a_3)$ is equal to

- (1) 131 (2) 130
(3) 129 (4) 128

Ans. (3)

Sol. Let the 1st term of G.P. be a & common ratio be r

$$\begin{aligned} a_3 a_5 &= ar^2 \cdot ar^4 = 729 \\ &= a^2 r^6 = 729 \\ &= ar^3 = 27 \quad \dots(i) \end{aligned}$$

$$\begin{aligned} a_2 + a_4 &= ar + ar^3 = \frac{111}{4} \\ &= ar = \frac{3}{4} \quad \dots(ii) \end{aligned}$$

(i) \div (ii)

$$\frac{ar^3}{ar} = \frac{27}{3/4}$$

$$r^2 = 36$$

$$r = 6$$

from (ii)

$$a(6) = \frac{3}{4} \Rightarrow a = \frac{1}{8}$$

Now, $24(a_1 + a_2 + a_3)$

$$= 24(a + ar + ar^2)$$

$$= 24a(1 + r + r^2)$$

$$= 24 \times \frac{1}{8} (1 + 6 + 36)$$

$$= 3(43)$$

$$= 129$$

17. Let the domain of the function

$$f(x) = \log_2 \log_4 \log_6 (3 + 4x - x^2)$$
 be (a, b) . If

$$\int_0^{b-a} [x^2] dx = p - \sqrt{q} - \sqrt{r}, p, q, r \in \mathbb{N}, \gcd(p, q, r) = 1,$$

where $[\cdot]$ is the greatest integer function,

then $p + q + r$ is equal to

- (1) 10 (2) 8
(3) 11 (4) 9

Ans. (1)

Sol. $\log_4 \log_6 (3 + 4x - x^2) > 0$

$$\log_6 (3 + 4x - x^2) > 1$$

$$3 + 4x - x^2 > 6$$

$$x^2 - 4x + 3 < 0$$

$$(x - 1)(x - 3) < 0$$

$$x \in (1, 3)$$

$$\text{so } a = 1 \text{ \& } b = 3$$

$$\Rightarrow \int_0^2 [x^2] dx = ?$$

$$I = \int_0^1 [x^2] dx + \int_1^{\sqrt{2}} [x^2] dx + \int_{\sqrt{2}}^{\sqrt{3}} [x^2] dx + \int_{\sqrt{3}}^{\sqrt{4}} [x^2] dx$$

$$= 0 + |x|_{1}^{\sqrt{2}} + 2|x|_{\sqrt{2}}^{\sqrt{3}} + 3|x|_{\sqrt{3}}^{\sqrt{4}}$$

$$= (\sqrt{2} - 1) + 2(\sqrt{3} - \sqrt{2}) + 3(2 - \sqrt{3})$$

$$= 5 - \sqrt{2} - \sqrt{3} \Rightarrow p + q + r = 10$$

18. The radius of the smallest circle which touches the parabolas $y = x^2 + 2$ and $x = y^2 + 2$ is

- (1) $\frac{7\sqrt{2}}{2}$ (2) $\frac{7\sqrt{2}}{16}$
(3) $\frac{7\sqrt{2}}{4}$ (4) $\frac{7\sqrt{2}}{8}$

Ans. (4)

Sol. The given parabolas are symmetric about the line

$$y = x.$$

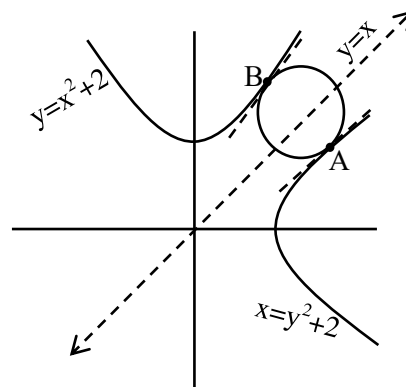

Tangents at A & B must be parallel to $y = x$ line, so

slope of the tangents = 1

$$\left(\frac{dy}{dx}\right)_{\min A} = 1 = \left(\frac{dy}{dx}\right)_{\min B}$$

For point B, $y = x^2 + 2$

$$\frac{dy}{dx} = 2x = 1$$

$$x = \frac{1}{2} \Rightarrow y = \frac{9}{4}$$

$$\therefore \text{Point B} = \left(\frac{1}{2}, \frac{9}{4}\right) \Rightarrow \text{Point A} = \left(\frac{9}{4}, \frac{1}{2}\right)$$

$$AB = \sqrt{\left(\frac{1}{2} - \frac{9}{4}\right)^2 + \left(\frac{9}{4} - \frac{1}{2}\right)^2}$$

$$= \sqrt{\frac{98}{16}} = \frac{7\sqrt{2}}{4}$$

$$\text{Radius} = \frac{7\sqrt{2}}{8}$$

19. Let $f(x) = \begin{cases} (1+ax)^{1/x}, & x < 0 \\ 1+b, & x = 0 \\ \frac{(x+4)^{1/2} - 2}{(x+c)^{1/3} - 2}, & x > 0 \end{cases}$

be continuous at $x = 0$. Then $e^a bc$ is equal to

- (1) 64 (2) 72
(3) 48 (4) 36

Ans. (3)

Sol. $f(0^-) = e^{\lim_{x \rightarrow 0^-} \frac{ax}{x}} = e^a$

$$f(0) = 1 + b$$

$$f(0^+) = \frac{1}{\frac{1}{3}(x+c)^{-\frac{2}{3}}} = \frac{1}{\frac{1}{3} \cdot c^{-\frac{2}{3}}}$$

$$= \frac{3}{4} c^{2/3}$$

Also at $x = 0$;

$$c^{1/3} = 2 \Rightarrow c = 8$$

$$\text{So } f(0^+) = \frac{3}{4}(8)^{2/3} = 3$$

$$\text{Now, } e^a = b + 1 = 3$$

$$e^a \cdot b \cdot c = 3 \cdot 2 \cdot 8 = 48$$

20. Line L_1 passes through the point $(1, 2, 3)$ and is parallel to z -axis. Line L_2 passes through the point $(\lambda, 5, 6)$ and is parallel to y -axis. Let for $\lambda = \lambda_1, \lambda_2, \lambda_2 < \lambda_1$, the shortest distance between the two lines be 3. Then the square of the distance of the point $(\lambda_1, \lambda_2, 7)$ from the line L_1 is

- (1) 40 (2) 32
(3) 25 (4) 37

Ans. (3)

Sol. $L_1 \equiv \frac{x-1}{0} = \frac{y-2}{0} = \frac{z-3}{1}$

$$L_2 \equiv \frac{x-\lambda}{0} = \frac{y-5}{1} = \frac{z-6}{0}$$

$$SD = \frac{\begin{vmatrix} \lambda-1 & 3 & 3 \\ 0 & 0 & 1 \\ 0 & 1 & 0 \end{vmatrix}}{\begin{vmatrix} \hat{i} & \hat{j} & \hat{k} \\ 0 & 0 & 1 \\ 0 & 1 & 0 \end{vmatrix}}$$

$$= |\lambda - 1| = 3$$

$$\lambda = 4, -2$$

$$\lambda_1 = 4$$

$$\lambda_2 = -2$$

Let foot of perpendicular from

$P(4, -2, 7)$ is $Q(1, 2, t+3)$

$$\text{So } (3, -4, 4-t) \cdot (0, 0, 1) = 0$$

$$\boxed{t=4}$$

So $Q(1, 2, 7)$

$$PQ^2 = 9 + 16$$

$$\boxed{PQ^2 = 25}$$

SECTION-B

21. All five letter words are made using all the letters A, B, C, D, E and arranged as in an English dictionary with serial numbers. Let the word at serial number n be denoted by W_n . Let the probability $P(W_n)$ of choosing the word W_n satisfy $P(W_n) = 2P(W_{n-1}), n > 1$.

If $P(CDBEA) = \frac{2^\alpha}{2^\beta - 1}, \alpha, \beta \in \mathbb{N}$, then $\alpha + \beta$ is equal to : _____

Ans. (183)

Sol. Let $P(W_1) = x$

$$\sum_{i=1}^{120} P(W_i) = 1$$

$$x + 2x + 2^2x + 2^3x + \dots + 2^{119}x = 1$$

$$\frac{x(2^{120} - 1)}{(2 - 1)} = 1 \Rightarrow x = \frac{1}{2^{120} - 1} \dots(1)$$

Rank of CDBEA

$$A \text{ } _ _ _ _ = |4| = 24$$

$$B \text{ } _ _ _ _ = |4| = 24$$

$$C A \text{ } _ _ _ _ = |3| = 6$$

$$C B \text{ } _ _ _ _ = |3| = 6$$

$$C D A \text{ } _ _ _ = |2| = 2$$

$$C D B A E = 1$$

$$C D B E A = 1$$

64

$$\text{So, } P(W_{64}) = 2P(W_{63}) = \dots = 2^{63} P(W_1)$$

$$= \frac{2^{63}}{2^{120} - 1}$$

$$\alpha + \beta = 63 + 120 = 183$$

22. Let the product of the focal distances of the point $P(4, 2\sqrt{3})$ on the hyperbola $H: \frac{x^2}{a^2} - \frac{y^2}{b^2} = 1$ be 32.

Let the length of the conjugate axis of H be p and the length of its latus rectum be q . Then $p^2 + q^2$ is equal to

Ans. (120)

Sol. $\frac{x^2}{a^2} - \frac{y^2}{b^2} = 1 \dots(1)$

$$P(4, 2\sqrt{3})$$

$$PS_1 \cdot PS_2 = 32$$

$$|PS_1 - PS_2| = 2a$$

$$P(4, 2\sqrt{3}) \text{ lies on H}$$

$$\therefore \frac{16}{a^2} - \frac{12}{b^2} = 1$$

$$16b^2 - 12a^2 = a^2b^2 \dots(2)$$

$$|PS_1 - PS_2|^2 = 4a^2$$

$$PS_1^2 + PS_2^2 - 2PS_1 \cdot PS_2 = 4a^2$$

$$(ae - 4)^2 + 12 + (ae + 4)^2 + 12 - 64 = 4a^2$$

$$2a^2e^2 - 8 = 4a^2$$

$$a^2 + b^2 - 4 = 2a^2$$

$$b^2 - a^2 = 4$$

$$(2) \& (3) \Rightarrow 16(a^2 + 4) - 12a^2 = a^2(a^2 + 4)$$

$$\Rightarrow 16a^2 + 64 - 12a^2 = a^4 + 4a^2$$

$$\Rightarrow a^4 = 64$$

$$\Rightarrow a^2 = 8$$

$$\therefore b^2 = 12$$

$$p^2 + q^2 = 4b^2 + \frac{4b^4}{a^2}$$

$$= 120$$

23. Let $\vec{a} = \hat{i} + \hat{j} + \hat{k}, \vec{b} = 3\hat{i} + 2\hat{j} - \hat{k}, \vec{c} = \lambda\hat{j} + \mu\hat{k}$ and \hat{d} be a unit vector such that $\vec{a} \times \hat{d} = \vec{b} \times \hat{d}$ and $\vec{c} \cdot \hat{d} = 1$. If \vec{c} is perpendicular to \vec{a} , then $|3\lambda\hat{d} + \mu\vec{c}|^2$ is equal to _____.

Ans. (5)

Sol. $\vec{a} \times \vec{d} - \vec{b} \times \vec{d} = 0$

$$(\vec{a} - \vec{b}) \times \vec{d} = 0$$

$$\vec{d} = t(\vec{a} - \vec{b})$$

$$\vec{d} = t(-2\hat{i} - \hat{j} + 2\hat{k})$$

$$|\vec{d}| = 1$$

$$\boxed{|t| = \frac{1}{3}}$$

$$\vec{c} \cdot \vec{a} = 0$$

$$\lambda + \mu = 0$$

$$\mu = -\lambda$$

$$\vec{c} = \lambda(\hat{j} - \hat{k}), \quad \boxed{|\vec{c}|^2 = 2\lambda^2}$$

$$\vec{c} \cdot \hat{d} = 1$$

$$t(-2, -1, 2) \cdot \lambda(0, 1, -1) = 1$$

$$\lambda t = \frac{-1}{3} \Rightarrow \boxed{\lambda^2 = 1}$$

$$|3\lambda\hat{d} + \mu\vec{c}|^2 = 9\lambda^2|\hat{d}|^2 + \mu^2|\vec{c}|^2 + 6\lambda\mu(\hat{d} \cdot \vec{c})$$

$$= 3\lambda^2 + 2\lambda^4$$

$$= 5$$

24. If the number of seven-digit numbers, such that the sum of their digits is even, is $m \cdot n \cdot 10^n$; $m, n \in \{1, 2, 3, \dots, 9\}$, then $m + n$ is equal to _____

Ans. (14)

Sol. Total 7 digit nos. = 9000000

7 digit nos. having sum of digits

Even = 4500000

= $9.5 \cdot 10^5$

$m = 9, n = 5$

$m + n = 14$

25. The area of the region bounded by the curve $y = \max\{|x|, |x-2|\}$, then x-axis and the lines $x = -2$ and $x = 4$ is equal to _____.

Ans. (12)

Sol.

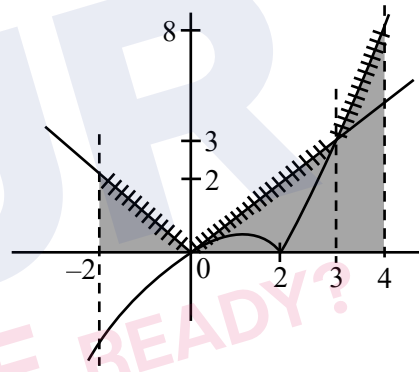

$$\text{Required Area} = \frac{1}{2} \times 2 \times 2 + \frac{1}{2} \times 3 \times 3 + \frac{1}{2} \times 1 \times 11$$

$$= 12$$

JEE-MAIN EXAMINATION – APRIL 2025

(HELD ON THURSDAY 03rd APRIL 2025)

TIME : 9:00 AM TO 12:00 NOON

PHYSICS

TEST PAPER WITH SOLUTION

SECTION-A

26. During the melting of a slab of ice at 273 K at atmospheric pressure :

- (1) Internal energy of ice-water system remains unchanged.
- (2) Positive work is done by the ice-water system on the atmosphere.
- (3) Internal energy of the ice-water system decreases.
- (4) Positive work is done on the ice-water system by the atmosphere.

Ans. (4)

Sol. Volume decreases during melting of ice so positive work is done on ice water system by atmosphere

Heat absorbed by ice water so ΔQ is positive, work done by ice water system is negative

Hence by first law of thermodynamics

$$\Delta U = \Delta Q + \Delta W = \text{Positive}$$

So internal energy increases

27. Consider a completely full cylindrical water tank of height 1.6 m and cross-sectional area 0.5 m^2 . It has a small hole in its side at a height 90 cm from the bottom. Assume, the cross-sectional area of the hole to be negligibly small as compared to that of the water tank. If a load 50 kg is applied at the top surface of the water in the tank then the velocity of the water coming out at the instant when the hole is opened is : ($g = 10 \text{ m/s}^2$)

- (1) 3 m/s
- (2) 5 m/s
- (3) 2 m/s
- (4) 4 m/s

Ans. (4)

Sol.

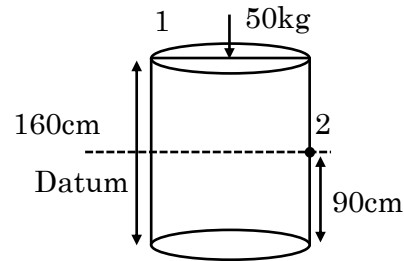

Apply Bernoulli equation between points 1 & 2

$$P_1 + \frac{1}{2} \rho v_1^2 + \rho gh = P_2 + \frac{1}{2} \rho v_2^2 + 0$$

$$P_0 + \frac{mg}{A} + \rho g \frac{70}{100} = P_0 + \frac{1}{2} \rho v_2^2$$

$$\frac{5000}{0.5} + 10^3 \times 10 \frac{70}{100} = \frac{1}{2} \times 10^3 v_2^2$$

$$10^3 + 10^3 \times 7 = \frac{10^3}{2} v_2^2$$

$$v_2^2 = 16$$

$$v_2 = 4 \text{ m/s}$$

As the tank area is large v_1 is negligible compared to v_2

28. Choose the correct logic circuit for the given truth table having inputs A and B.

Inputs		Output
A	B	Y
0	0	0
0	1	0
1	0	1
1	1	1

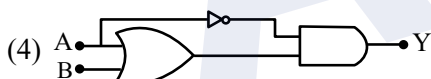
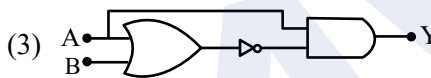
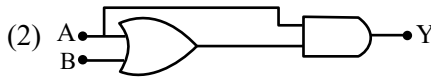
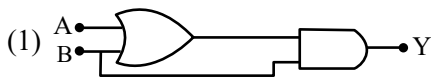

Ans. (2)

Sol. Only option (2) matches with the truth table

29. The radiation pressure exerted by a 450 W light source on a perfectly reflecting surface placed at 2m away from it, is :

- (1) 1.5×10^{-8} Pascals
- (2) 0
- (3) 6×10^{-8} Pascals
- (4) 3×10^{-8} Pascals

Ans. (3)

Sol. $P_{\text{rad}} = \frac{2I}{C}$

Where I = intensity at surface

C = Speed of light

$$I = \frac{\text{Power}}{\text{Area}} = \frac{450}{4\pi r^2}$$

$$= \frac{450}{4\pi \times 4} = \frac{450}{16\pi}$$

$$P_{\text{rad}} = \frac{2 \times 450}{16\pi \times 3 \times 10^8} = \frac{150}{8\pi \times 10^8}$$

$$= 5.97 \times 10^{-8} \approx 6 \times 10^{-8} \text{ Pascals}$$

30. A wire of length 25 m and cross-sectional area 5 mm^2 having resistivity of $2 \times 10^{-6} \Omega \text{ m}$ is bent into a complete circle. The resistance between diametrically opposite points will be

- (1) 12.5Ω
- (2) 50Ω
- (3) 100Ω
- (4) 25Ω

Allen Ans. (Bonus)

NTA Ans. (4)

Sol.

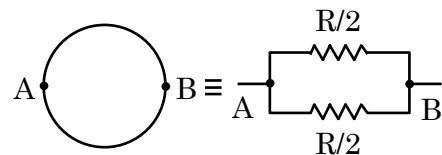

$$L = 25 \text{ m}, A = 5 \text{ mm}^2 = 5 \times 10^{-6} \text{ m}^2$$

$$\rho = 2 \times 10^{-6} \Omega \text{ m}$$

$$R_{\text{wire}} = \frac{\rho L}{A} = \frac{2 \times 10^{-6} \times 25}{5 \times 10^{-6}} = 10$$

$$R_{\text{eq}} = \frac{R}{4} = \frac{10}{4} = 2.5 \Omega$$

Answer does not match with NTA option.

31. Two blocks of masses m and M , ($M > m$), are placed on a frictionless table as shown in figure. A massless spring with spring constant k is attached with the lower block. If the system is slightly displaced and released then

(μ = coefficient of friction between the two blocks)

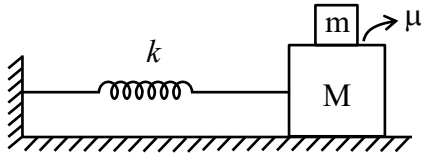

(A) The time period of small oscillation of the two

blocks is $T = 2\pi\sqrt{\frac{(m+M)}{k}}$

(B) The acceleration of the blocks is $a = \frac{kx}{M+m}$

(x = displacement of the blocks from the mean position)

(C) The magnitude of the frictional force on the upper block is $\frac{m\mu|x|}{M+m}$

(D) The maximum amplitude of the upper block, if it does not slip, is $\frac{\mu(M+m)g}{k}$

(E) Maximum frictional force can be $\mu(M+m)g$.

Choose the **correct** answer from the options given below :

- (1) A, B, D Only
- (2) B, C, D Only
- (3) C, D, E Only
- (4) A, B, C Only

Ans. (1)

Sol. (A) As both blocks moving together so

Time period = $2\pi\sqrt{\frac{m}{K}}$; where $m = M + m$

$$T = 2\pi\sqrt{\frac{M+m}{K}}$$

(B) Let block is displaced by x in (+ve) direction so force on block will be in(-ve) direction

$$F = -Kx$$

$$(M+m)a = -Kx$$

$$a = -\frac{Kx}{(M+m)}$$

(C) As upper block is moving due to friction thus

$$f = ma = \frac{mKx}{(M+m)}$$

(D) This option is like two block problem in friction for maximum amplitude, force on block is also maximum, for which both blocks are moving together.

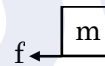
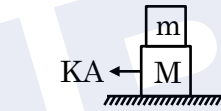

$$KA = (M+m)a$$

$$a = \frac{KA}{(M+m)}$$

$$f = ma = \frac{mKA}{(M+m)}$$

$$f_{\max} = f_L = \mu mg$$

$$f = \mu mg$$

$$\frac{mKA}{(M+m)} = \mu mg$$

$$A = \frac{\mu(M+m)g}{K}$$

(E) Maximum friction can be μmg as force is acting between blocks & normal force here is mg .

32. Which of the following curves possibly represent one-dimensional motion of a particle ?

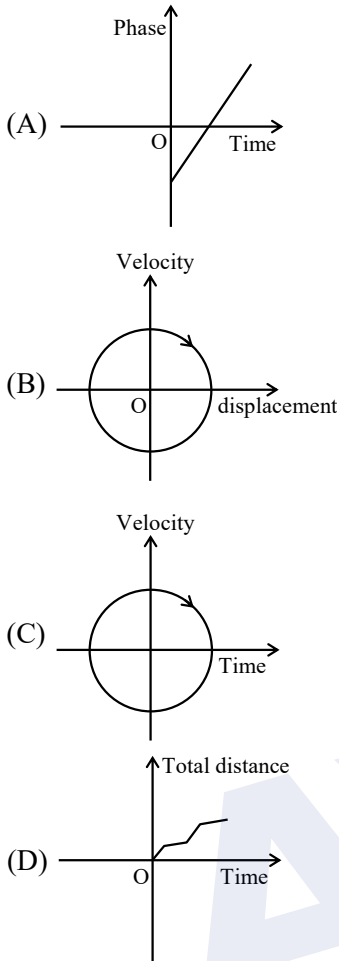

Choose the **correct** answer from the options given below :

- (1) A, B and D only (2) A, B and C only
(3) A and B only (4) A, C and D only

Ans. (1)

Sol. For option (A)

$\phi = kt + C$ it can be 1D motion

eg $\rightarrow x = A \sin \phi$ (SHM)

For option (B)

$v^2 + x^2 = \text{constant}$ yes 1D

For option (C)

time can't be negative Not possible

For option (D)

Possible

A, B & D only

33. A parallel plate capacitor is filled equally (half) with two dielectrics of dielectric constant ϵ_1 and ϵ_2 , as shown in figures. The distance between the plates is d and area of each plate is A . If capacitance in first configuration and second configuration are C_1 and C_2 respectively, then $\frac{C_1}{C_2}$ is :

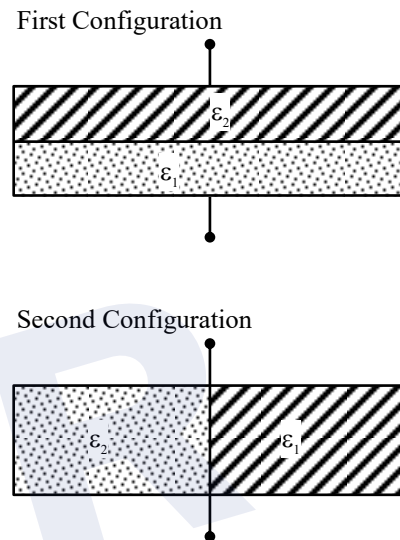

- (1) $\frac{\epsilon_1 \epsilon_2^2}{(\epsilon_1 + \epsilon_2)^2}$ (2) $\frac{4\epsilon_1 \epsilon_2}{(\epsilon_1 + \epsilon_2)^2}$
(3) $\frac{\epsilon_1 \epsilon_2}{\epsilon_1 + \epsilon_2}$ (4) $\frac{\epsilon_0(\epsilon_1 + \epsilon_2)}{2}$

Ans. (2)

Sol.

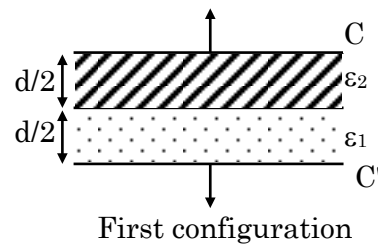

Area of plate is A .

then

$$C = \frac{\epsilon_2 \epsilon_0 A}{d/2} = \frac{2\epsilon_2 \epsilon_0 A}{d}$$

$$C' = \frac{\epsilon_1 \epsilon_0 A}{d/2} = \frac{2\epsilon_1 \epsilon_0 A}{d}$$

$$\text{Let } C_0 = \frac{\epsilon_0 A}{d}$$

$$C = 2\epsilon_2 C_0$$

$$C' = 2\epsilon_1 C_0$$

C & C' are in series

$$C_1 = \frac{CC'}{C+C'} = \frac{4\epsilon_2\epsilon_1 C_0^2}{2C_0(\epsilon_2 + \epsilon_1)}$$

$$= \frac{2\epsilon_2\epsilon_1 C_0}{(\epsilon_2 + \epsilon_1)}$$

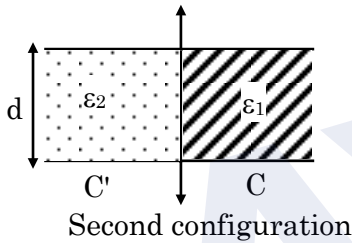

$$\text{Here } C = \frac{\epsilon_1 \epsilon_0 A}{2d} = \frac{\epsilon_1 C_0}{2}$$

$$C' = \frac{\epsilon_2 C_0}{2}$$

C & C' are in parallel

$$C_2 = C' + C = (\epsilon_1 + \epsilon_2) \frac{C_0}{2}$$

$$\text{Thus } \frac{C_1}{C_2} = \frac{2\epsilon_2\epsilon_1 C_0}{(\epsilon_2 + \epsilon_1)} \times \frac{2}{(\epsilon_1 + \epsilon_2) C_0}$$

$$= \frac{4\epsilon_2\epsilon_1}{(\epsilon_2 + \epsilon_1)^2}$$

34. Match the LIST-I with LIST-II

	LIST-I		LIST-II
A.	Gravitational constant	I.	$[LT^{-2}]$
B.	Gravitational potential energy	II.	$[L^2T^{-2}]$
C.	Gravitational potential	III.	$[ML^2T^{-2}]$
D.	Acceleration due to gravity	IV.	$[M^{-1}L^3T^{-2}]$

Choose the **correct** answer from the options given below :

- (1) A-IV, B-III, C-II, D-I (2) A-III, B-II, C-I, D-IV
(3) A-II, B-IV, C-III, D-I (4) A-I, B-III, C-IV, D-II

Ans. (1)

Sol. (A) $G = \frac{Fr^2}{m^2}$

$$[G] = \frac{[MLT^{-2}][L^2]}{[M^2]} = [M^{-1}L^3T^{-2}] \text{ (IV)}$$

(B) P.E. = $mgh = [MLT^{-2}L]$
= $[ML^2T^{-2}]$ (III)

(C) Gravitational Potential = $\frac{GM}{r}$

$$= \frac{[M^{-1}L^3T^{-2}][M]}{[L]} = [M^0L^2T^{-2}] = [L^2T^{-2}] \text{ (II)}$$

(D) Acceleration due to gravity = $[g] = [LT^{-2}]$ (I)

35. A force of 49 N acts tangentially at the highest point of a sphere (solid) of mass 20 kg, kept on a rough horizontal plane. If the sphere rolls without slipping, then the acceleration of the center of the sphere is

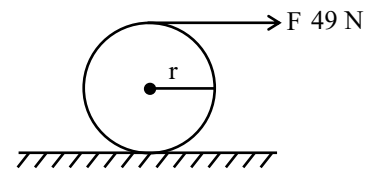

- (1) 3.5 m/s² (2) 0.35 m/s²
(3) 2.5 m/s² (4) 0.25 m/s²

Ans. (1)

Sol.

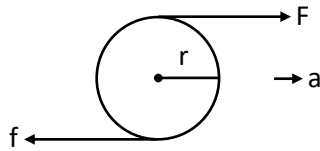

Torque about bottom point

$$F \times 2r = I\alpha$$

$$49 \times 2r = \frac{7}{5}mr^2\alpha$$

$$14 = 4r\alpha$$

As sphere rolls without slipping

$$a = r\alpha$$

$$a = \frac{14}{4} = \frac{7}{2} = 3.5 \text{ m/s}^2$$

36. A piston of mass M is hung from a massless spring whose restoring force law goes as $F = -kx^3$, where k is the spring constant of appropriate dimension. The piston separates the vertical chamber into two parts, where the bottom part is filled with 'n' moles of an ideal gas. An external work is done on the gas isothermally (at a constant temperature T) with the help of a heating filament (with negligible volume) mounted in lower part of the chamber, so that the piston goes up from a height L_0 to L_1 , the total energy delivered by the filament is (Assume spring to be in its natural length before heating)

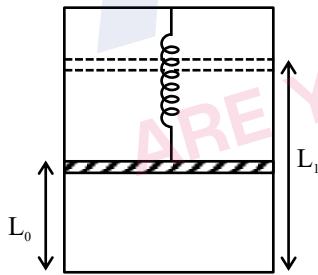

(1) $3nRT \ln\left(\frac{L_1}{L_0}\right) + 2Mg(L_1 - L_0) + \frac{k}{3}(L_1^3 - L_0^3)$

(2) $nRT \ln\left(\frac{L_1^2}{L_0^2}\right) + \frac{Mg}{2}(L_1 - L_0) + \frac{k}{4}(L_1^4 - L_0^4)$

(3) $nRT \ln\left(\frac{L_1}{L_0}\right) + Mg(L_1 - L_0) + \frac{k}{4}(L_1^4 - L_0^4)$

(4) $nRT \ln\left(\frac{L_1}{L_0}\right) + Mg(L_1 - L_0) + \frac{3k}{4}(L_1^4 - L_0^4)$

Ans. (3)

Sol. Using WET

Total energy supplied = gravitational potential energy + spring potential energy + work done by gas

$$Mg(L_1 - L_0) + \int_{L_0}^{L_1} kx^3 dx + nRT \ln$$

$$\left[\frac{L_1 A}{L_0 A} \right] + W_{\text{ext}} = 0$$

$$\frac{K}{4} [x^4]_{L_0}^{L_1} + Mg(L_1 - L_0) + \int_{L_0}^{L_1} kx^3 dx + nRT \ln$$

$$\left[\frac{L_1}{L_0} \right] + W_{\text{ext}} = 0$$

$$\frac{k}{4}(L_1^4 - L_0^4) + Mg(L_1 - L_0) + nRT \ln$$

$$\left[\frac{L_1}{L_0} \right] + W_{\text{ext}} = 0$$

$$W_{\text{ext}} = \frac{k}{4}(L_1^4 - L_0^4) + Mg(L_1 - L_0) + nRT \ln \left[\frac{L_1}{L_0} \right]$$

37. A gas is kept in a container having walls which are thermally non-conducting. Initially the gas has a volume of 800 cm^3 and temperature 27°C . The change in temperature when the gas is adiabatically compressed to 200 cm^3 is :

(Take $\gamma = 1.5$: γ is the ratio of specific heats at constant pressure and at constant volume)

- (1) 327 K
(2) 600 K
(3) 522 K
(4) 300 K

Ans. (4)

Sol. $V_1 = 800 \text{ cm}^3$ $V_2 = 200 \text{ cm}^3$

$$T_1 = 300 \text{ K}$$

for adiabatic

$$TV^{\gamma-1} = \text{const.}$$

$$(300)(800)^{1.5-1} = T_2(200)^{1.5-1}$$

$$T_2 = 300 \left[\frac{800}{200} \right]^{0.5} = 300 \times (2^2)^{1/2}$$

$$T_2 = 600 \text{ K}$$

$$\Delta T = 600 - 300 = 300 \text{ K}$$

38. Match the LIST-I with LIST-II

	LIST-I		LIST-II
A.	${}_0^1n + {}_{92}^{235}\text{U} \rightarrow {}_{54}^{140}\text{Xe} + {}_{38}^{94}\text{Sr} + 2{}_0^1n$	I.	Chemical reaction
B.	$2\text{H}_2 + \text{O}_2 \rightarrow 2\text{H}_2\text{O}$	II.	Fusion with +ve Q value
C.	${}_1^2\text{H} + {}_1^2\text{H} \rightarrow {}_2^3\text{He} + {}_0^1n$	III.	Fission
D.	${}_1^1\text{H} + {}_1^3\text{H} \rightarrow {}_1^2\text{H} + {}_1^2\text{H}$	IV.	Fusion with -ve Q value

Choose the **correct** answer from the options given below :

- (1) A-II, B-I, C-III, D-IV
- (2) A-III, B-I, C-II, D-IV
- (3) A-II, B-I, C-IV, D-III
- (4) A-III, B-I, C-IV, D-II

Ans. (2)

Sol. Conceptual

39. The electrostatic potential on the surface of uniformly charged spherical shell of radius $R = 10$ cm is 120 V. The potential at the centre of shell, at a distance $r = 5$ cm from centre, and at a distance $r = 15$ cm from the centre of the shell respectively, are :

- (1) 120V, 120V, 80V
- (2) 40V, 40V, 80V
- (3) 0V, 0V, 80V
- (4) 0V, 120V, 40V

Ans. (1)

Sol. Potential inside shell is equal to potential on surface

$$V_{in} = V_{surface} = \frac{kQ}{R} = 120V$$

at $r = 15$ cm

$$V = \frac{kQ}{r} = \frac{120 \times 10}{15} = 80V$$

40. The work function of a metal is 3 eV. The color of the visible light that is required to cause emission of photoelectrons is

- (1) Green
- (2) Blue
- (3) Red
- (4) Yellow

Ans. (2)

Sol. $(KE)_{max} = \frac{hc}{\lambda} - \phi$

$$\frac{hc}{\lambda} > \phi \text{ [for emission]}$$

$$\lambda < \frac{hc}{\phi} \Rightarrow \lambda < \frac{1242}{3} \text{ nm}$$

So blue light option (B)

41. A particle is released from height S above the surface of the earth. At certain height its kinetic energy is three times its potential energy. The height from the surface of the earth and the speed of the particle at that instant are respectively.

- (1) $\frac{S}{2}, \sqrt{\frac{3gS}{2}}$
- (2) $\frac{S}{2}, \frac{3gS}{2}$
- (3) $\frac{S}{4}, \frac{3gS}{2}$
- (4) $\frac{S}{4}, \sqrt{\frac{3gS}{2}}$

Ans. (4)

Sol. $V^2 = 0 + 2g(S - x)$

$$V^2 = 2g(S - x)$$

At B, Potential energy = mgx

$$mgx = 3 \times \frac{1}{2}mv^2$$

$$gx = \frac{3}{2} \times 2g(S - x)$$

$$4x = S$$

$$x = \frac{S}{4}$$

$$\Rightarrow V = \sqrt{2g \times \frac{3S}{4}} = \sqrt{\frac{3gS}{2}}$$

42. A person measures mass of 3 different particles as 435.42 g, 226.3 g and 0.125 g. According to the rules for arithmetic operations with significant figures, the additions of the masses of 3 particles will be.

- (1) 661.845 g
- (2) 662 g
- (3) 661.8 g
- (4) 661.84 g

Ans. (3)

Sol. $m_1 + m_2 + m_3 = 435.42 + 226.3 + 0.125$
According to least significant digits $m = 661.8$ g

43. The radii of curvature for a thin convex lens are 10 cm and 15 cm respectively. The focal length of the lens is 12 cm. The refractive index of the lens material is

- (1) 1.2
- (2) 1.4
- (3) 1.5
- (4) 1.8

Ans. (3)

Sol. $\frac{1}{f} = (\mu - 1) \left(\frac{1}{R_1} - \frac{1}{R_2} \right)$

$$\frac{1}{12} = (\mu - 1) \left(\frac{1}{10} - \frac{1}{-15} \right)$$

$$\frac{1}{12} = (\mu - 1) \left(\frac{3+2}{30} \right)$$

$$\mu = \frac{3}{2}$$

44. The angle of projection of a particle is measured from the vertical axis as ϕ and the maximum height reached by the particle is h_m . Here h_m as function of ϕ can be presented as

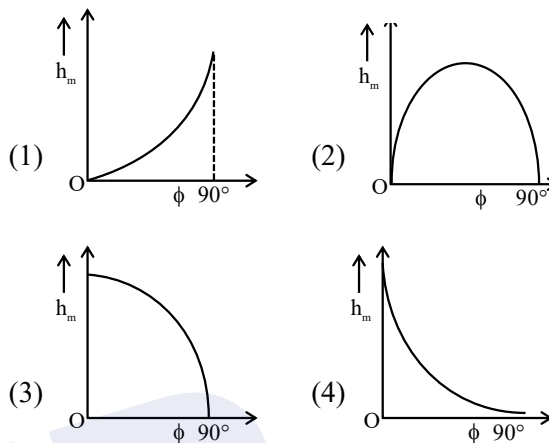

Ans. (3)

Sol.

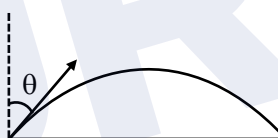

$$H_{\max} = \frac{u^2 \cos^2 \phi}{2g}$$

45. Consider following statements for refraction of light through prism, when angle of deviation is minimum.

- (A) The refracted ray inside prism becomes parallel to the base.
- (B) Larger angle prisms provide smaller angle of minimum deviation.
- (C) Angle of incidence and angle of emergence becomes equal.
- (D) There are always two sets of angle of incidence for which deviation will be same except at minimum deviation setting.
- (E) Angle of refraction becomes double of prism angle.

Choose the correct answer from the options given below.

- (1) A, C and D Only
- (2) B, C and D Only
- (3) A, B and E Only
- (4) B, D and E Only

Ans. (1)

Sol. $\delta = I + e - A$

For $\delta_{\min} \Rightarrow I = e$

and refracted ray is parallel to base

A, C, D are correct

SECTION-B

46. Three identical spheres of mass m , are placed at the vertices of an equilateral triangle of length a . When released, they interact only through gravitational force and collide after a time $T = 4$ seconds. If the sides of the triangle are increased to length $2a$ and also the masses of the spheres are made $2m$, then they will collide after _____ seconds.

Ans. (8)

Sol. $T \propto m^x G^y a^z$

$$T \propto M^x [M^{-1}L^3T^{-2}]^y [L]^z$$

$$T \propto M^{x-y} L^{3y+z} T^{-2y}$$

$$x - y = 0 \Rightarrow x = y$$

$$-2y = 1 \Rightarrow y = -\frac{1}{2}, x = -\frac{1}{2}$$

$$\Rightarrow 3y + z = 0$$

$$z = -3y = \frac{3}{2}$$

Hence

$$T \propto m^{-1/2} G^{-1/2} a^{3/2}$$

$$T \propto \left(\frac{a^3}{m}\right)^{1/2}$$

$$T = 4 \times \left(\frac{2^3}{2}\right)^{1/2} = 8s$$

47. A 4.0 cm long straight wire carrying a current of 8A is placed perpendicular to an uniform magnetic field of strength 0.15 T. The magnetic force on the wire is _____ mN.

Ans. (48)

Sol. $F = I\ell B$

$$= 8 \times \frac{4}{100} \times 0.15$$

$$= 48 \times 10^{-3} \text{ N} = 48 \text{ mN}$$

48. Two coherent monochromatic light beams of intensities $4I$ and $9I$ are superimposed. The difference between the maximum and minimum intensities in the resulting interference pattern is xI . The value of x is _____.

Ans. (24)

$$\begin{aligned} \text{Sol. } I_{\max} &= (\sqrt{I_1} + \sqrt{I_2})^2 \\ &= (\sqrt{4I} + \sqrt{9I})^2 = 25I \end{aligned}$$

$$\begin{aligned} I_{\min} &= (\sqrt{I_1} - \sqrt{I_2})^2 \\ &= (\sqrt{4I} - \sqrt{9I})^2 = I \end{aligned}$$

$$I_{\max} - I_{\min} = 24I$$

$$x = 24$$

49. A loop ABCDA, carrying current $I = 12 \text{ A}$, is placed in a plane, consists of two semi-circular segments of radius $R_1 = 6\pi \text{ m}$ and $R_2 = 4\pi \text{ m}$. The magnitude of the resultant magnetic field at center O is $k \times 10^{-7} \text{ T}$. The value of k is _____.

(Given $\mu_0 = 4\pi \times 10^{-7} \text{ Tm A}^{-1}$)

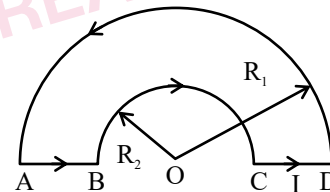

Ans. (1)

Sol. Magnetic field due to AB & CD = 0

$$B_0 = |B_{R_1} - B_{R_2}|$$

$$= \frac{\mu_0 I}{4R_2} - \frac{\mu_0 I}{4R_1}$$

$$= \frac{4\pi \times 10^{-7} \times 12}{4} \left(\frac{1}{4\pi} - \frac{1}{6\pi} \right)$$

$$= 12\pi \times 10^{-7} \left(\frac{1}{12\pi} \right) = 1 \times 10^{-7}$$

$$K = 1$$

50. In the figure shown below, a resistance of 150.4Ω is connected in series to an ammeter A of resistance 240Ω . A shunt resistance of 10Ω is connected in parallel with the ammeter. The reading of the ammeter is _____ mA.

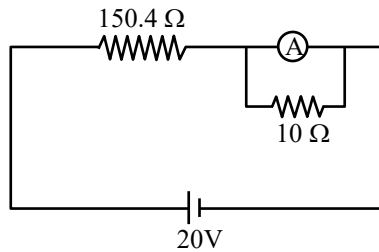

Allen Ans. (5)

NTA Ans. (125)

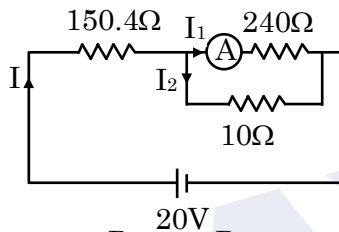

Sol.

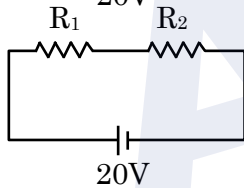

$$R_{eq} = R_1 + R_2$$

$$R_{eq} = 150.4 + \frac{240 \times 10}{250}$$

$$= 150.4 + 9.6 = 160 \Omega$$

$$I_1 = \frac{IR_2}{240}$$

$$I_1 = \frac{I \times 9.6}{240}$$

$$= \frac{20}{160} \times \frac{9.6}{2400} = \frac{1}{200} = 5 \times 10^{-3} \text{ A} = 5 \text{ mA}$$

JEE-MAIN EXAMINATION – APRIL 2025

(HELD ON THURSDAY 03rd APRIL 2025)

TIME : 9:00 AM TO 12:00 NOON

CHEMISTRY

TEST PAPER WITH SOLUTION

SECTION-A

51. Which of the following postulate of Bohr's model of hydrogen atom is not in agreement with quantum mechanical model of an atom ?

- (1) An atom in a stationary state does not emit electromagnetic radiation as long as it stays in the same state
- (2) An atom can take only certain distinct energies $E_1, E_2, E_3,$ etc. These allowed states of constant energy are called the stationary states of atom
- (3) When an electron makes a transition from a higher energy stationary state to a lower energy stationary state, then it emits a photon of light
- (4) The electron in a H atom's stationary state moves in a circle around the nucleus

Ans. (4)

Sol. The electron in a H-atom's stationary state moves in a spherical path.

52. Given below are two statements

Statement I : The N–N single bond is weaker and longer than that of P–P single bond

Statement II : Compounds of group 15 elements in +3 oxidation states readily undergo disproportionation reactions.

In the light of above statements, choose the correct answer from the options given below

- (1) Statement I is true but statement II is false
- (2) Both statement I and statement II are false
- (3) Statement I is false but statement II is true
- (4) Both statement I and statement II are true

Ans. (2)

Sol. $\overset{\cdot\cdot}{\text{N}}-\overset{\cdot\cdot}{\text{N}}$ single bond weaker than $\overset{\cdot\cdot}{\text{P}}-\overset{\cdot\cdot}{\text{P}}$ due to more $\ell\text{p}-\ell\text{p}$ repulsion.

Bond length $\Rightarrow d_{\text{p-p}} > d_{\text{N-N}}$ (size \uparrow , B.L. \uparrow)

In group 15 elements only N & P show disproportionation in +3 oxidation state, **As, Sb & Bi** have almost inert for disproportionation in +3 oxidation state.

So both statements are false.

53. Given below are two statements

Statement I : A catalyst cannot alter the equilibrium constant (K_c) of the reaction, temperature remaining constant

Statement II : A homogenous catalyst can change the equilibrium composition of a system temperature remaining constant

In the light of the above statements, choose the **correct** answer from the options given below

- (1) Statement I is false but Statement II is true
- (2) Both Statement I and Statement II are true
- (3) Both Statement I and Statement II is false
- (4) Statement I is true but Statement II is false

Ans. (2)

Sol. A catalyst can change equilibrium composition if it is added at constant pressure, but it can not change equilibrium constant.

54. The metal ions that have the calculated spin only magnetic moment value of 4.9 B.M. are

- A. Cr^{2+}
- B. Fe^{2+}
- C. Fe^{3+}
- D. Co^{2+}
- E. Mn^{3+}

Choose the **correct** answer from the options given below

- (1) A, C and E only
- (2) A, D and E only
- (3) B and E only
- (4) A, B and E only

Ans. (4)

Sol. Given magnetic moment = 4.9 B.M.

We know $M.M = \sqrt{n(n+2)}\text{B.M.}$

Where, $n \rightarrow$ No. of unpaired e^-

$$4.9 = \sqrt{n(n+2)}$$

We get $n = 4$

- (A) ${}_{24}\text{Cr}^{2+} \Rightarrow [\text{Ar}]3d^4$ (4 unpaired e^-)
- (B) ${}_{26}\text{Fe}^{2+} \Rightarrow [\text{Ar}]3d^6$ (4 unpaired e^-)
- (C) ${}_{26}\text{Fe}^{3+} \Rightarrow [\text{Ar}]3d^5$ (5 unpaired e^-)
- (D) ${}_{27}\text{Co}^{2+} \Rightarrow [\text{Ar}]3d^7$ (3 unpaired e^-)
- (E) ${}_{25}\text{Mn}^{3+} \Rightarrow [\text{Ar}]3d^4$ (4 unpaired e^-)

55. In a reaction $A + B \rightarrow C$, initial concentrations of A and B are related as $[A]_0 = 8[B]_0$. The half lives of A and B are 10 min and 40 min. respectively. If they start to disappear at the same time, both following first order kinetics, after how much time will the concentration of both the reactants be same?

- (1) 60 min (2) 80 min
(3) 20 min (4) 40 min

Ans. (4)

Sol. Given : $[A]_0 = 8[B]_0$

$$[t_{1/2}]_A = 10 \text{ min.}$$

$$[t_{1/2}]_B = 40 \text{ min.}$$

1st order kinetics

$$t = ?$$

$$[A]_t = [B]_t$$

$$-k_A \times t = -k_B \times t$$

$$\Rightarrow [A]_0 e^{-k_A t} = [B]_0 e^{-k_B t}$$

$$\Rightarrow \frac{[A]_0}{[B]_0} = e^{(k_A - k_B)t}$$

$$\Rightarrow 8 = e^{(k_A - k_B)t}$$

$$\Rightarrow \ln 8 = (k_A - k_B) \times t$$

$$\Rightarrow \ln 8 = \ln 2 \left(\frac{1}{(t_{1/2})_A} - \frac{1}{(t_{1/2})_B} \right) \times t$$

56. Which of the following is the correct structure of L-fructose ?

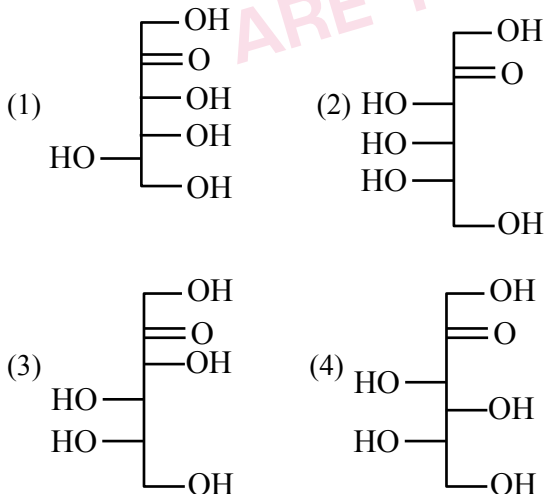

Ans. (3)

Sol.

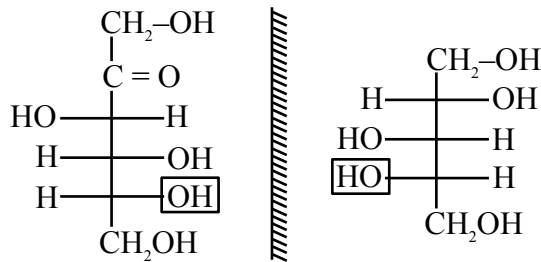

D - Fructose

L - Fructose

57. Identify the correct statements from the following

- A. are metamers
- B. are functional isomers
- C. are position isomers
- D. are homologous

Choose the **correct** answer from the options given below

(1) C & D only

(2) B & C only

(3) A & B only

(4) A, B & C only

Ans. (3)

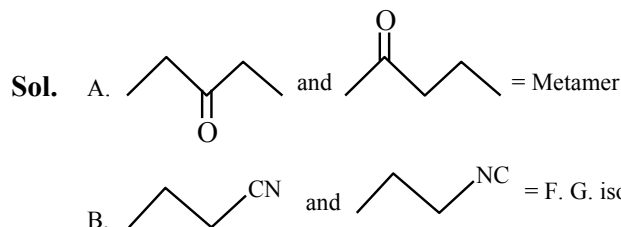

In option C are homologues to each – other and option D are only organic molecule not isomers.

58. Among 10^{-9} g (each) of the following elements, which one will have the highest number of atoms?

Element : Pb, Po, Pr and Pt

- (1) Po
- (2) Pr
- (3) Pb
- (4) Pt

Ans. (2)

Sol. No. of atoms = $\frac{\text{Mass in g}}{\text{Molar Mas(g / mol)}} \times N_A$

Therefore for the same Mass element having the least Molar mass will have the higher no. of atoms.

- $M_{Po} = 209$
- $M_{Pr} = 141$
- $M_{Pb} = 207$
- $M_{Pt} = 195$

59. Which of the following statements are correct?

- A. The process of the addition an electron to a neutral gaseous atom is always exothermic
- B. The process of removing an electron from an isolated gaseous atom is always endothermic
- C. The 1st ionization energy of the boron is less than that of the beryllium
- D. The electronegativity of C is 2.5 in CH_4 and CCl_4
- E. Li is the most electropositive among elements of group I

Choose the **correct** answer from the options gives below

- (1) B and C only
- (2) A, C and D only
- (3) B and D only
- (4) B, C and E only

Ans. (1)

Sol. (A) The process of adding an e^- to a neutral gaseous atom is not always exothermic it may be exothermic or endothermic.

(C) Be B

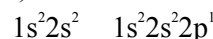

In Be 2s subshell in fully filled

So, need high energy to remove e^- as compared to B.

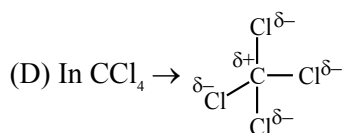

due to partially positive charge $z_{eff} \uparrow$, $EN \uparrow$

So, EN of C $\Rightarrow CCl_4 > CH_4$

(E) Cs is most electropositive.

60. Which of the following properties will change when system containing solution 1 will become solution 2 ?

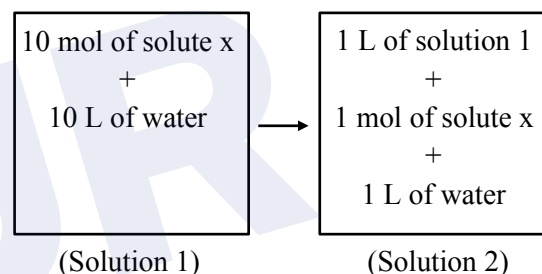

- (1) Molar heat capacity
- (2) Density
- (3) Concentration
- (4) Gibbs free energy

Ans. (4)

Sol. Both solutions are having same composition, which is 1 mole of 'x' in 1 'l' water, so all the intensive properties will remain same, but as total amount is greater in solution '1' compared to solution '2'. So extensive properties will be different hence Gibbs free energy will be different.

61. Number of molecules from below which cannot give iodoform reaction is :

Ethanol, Isopropyl alcohol, Bromoacetone, 2-Butanol, 2-Butanone, Butanal, 2-Pentanone, 3-Pentanone, Pentanal and 3-Pentanol

- (1) 5
- (2) 4
- (3) 3
- (4) 2

Ans. (2)

Sol. Following will not give iodoform reaction/test.

- (1) Butanal
- (2) 2-Pentanone
- (3) Pentanal
- (4) 3- Pentanol

62. Identify [A], [B], and [C], respectively in the following reaction sequence :

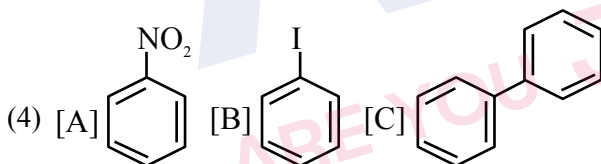
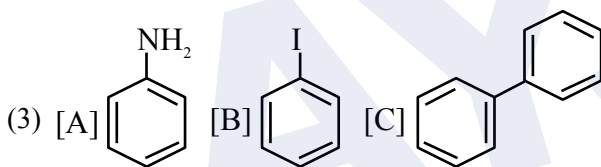
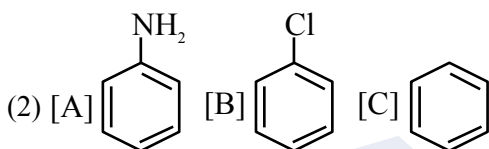
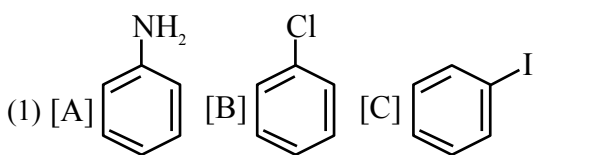
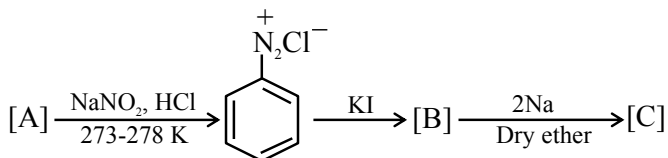

Ans. (3)

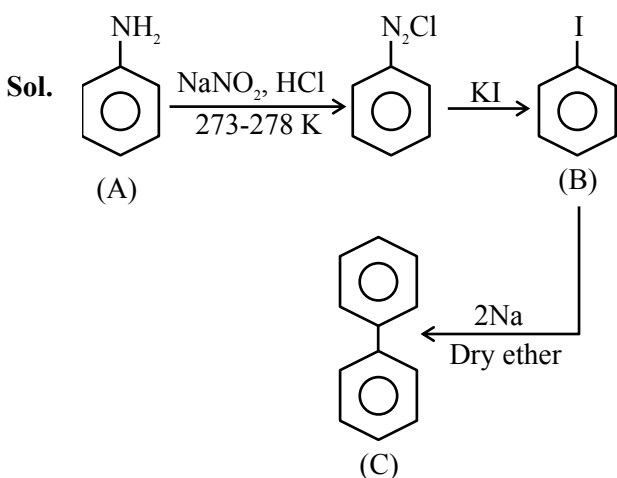

63. In the following reactions, which one is NOT correct?

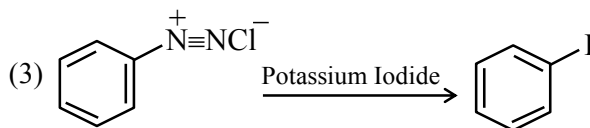
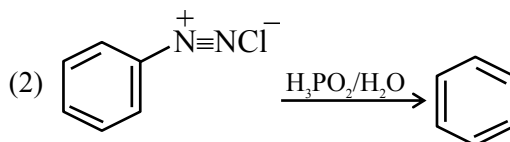
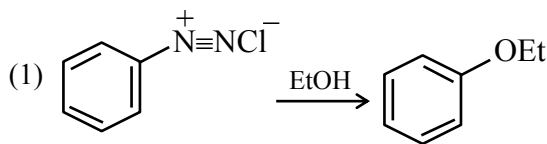

Ans. (1)

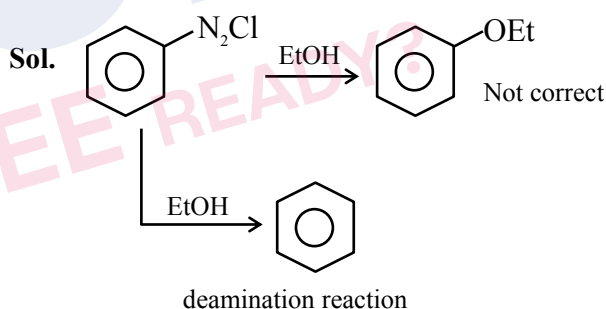

64. The correct order of the complexes $[\text{Co}(\text{NH}_3)_5(\text{H}_2\text{O})]^{3+}$ (A), $[\text{Co}(\text{NH}_3)_6]^{3+}$ (B), $[\text{Co}(\text{CN})_6]^{3-}$ (C) and $[\text{CoCl}(\text{NH}_3)_5]^{2+}$ (D) in terms wavelength of light absorbed is :

- (1) $D > A > B > C$
- (2) $C > B > D > A$
- (3) $D > C > B > A$
- (4) $C > B > A > D$

Ans. (1)

Sol. We know $E = hv = \frac{hc}{\lambda}$

$$E \propto \frac{1}{\lambda}$$

Here all Co in +3 oxidation state.

So, as the ligand field strength \uparrow , CFSE \uparrow

Order of field strength of ligand :

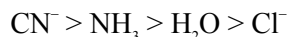

CFSE order : C > B > A > D

Wavelength order : D > A > B > C

65. In the following system,

$PCl_5(g) \rightleftharpoons PCl_3(g) + Cl_2(g)$ at equilibrium, upon addition of xenon gas at constant T & p, the concentration of

- (1) PCl_5 will increase
- (2) Cl_2 will decrease
- (3) PCl_5 , PCl_3 & Cl_2 remain constant
- (4) PCl_3 will increase

Ans. (4)

Sol. On addition of inert gas at constant P & T, reaction moves in the direction of greater no. of moles so it will shift in forward direction, so $[PCl_5]$ decrease and $[PCl_3]$ & $[Cl_2]$ will increase.

66. 2 moles each of ethylene glycol and glucose are dissolved in 500 g of water. The boiling point of the resulting solution is :

(Given : Ebullioscopic constant of water = $0.52 \text{ K kg mol}^{-1}$)

- (1) 379.2 K
- (2) 377.3 K
- (3) 375.3 K
- (4) 277.3 K

Ans. (2)

Sol. $\Delta T_b = i_1 m_1 k_b + i_2 m_2 k_b$
 $= 1 \times \frac{2}{0.5} \times 0.52 + \frac{1 \times 2}{0.5} \times 0.52 = 4.16$
 $(T_b)_{\text{solution}} = 373.16 + 4.16 = 377.3 \text{ K.}$

67. Which compound would give 3-methyl-6-oxoheptanal upon ozonolysis ?

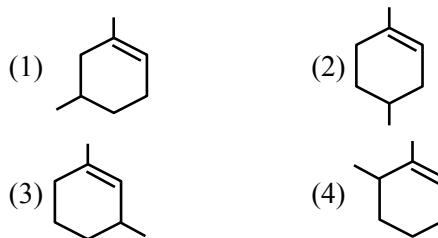

Ans. (2)

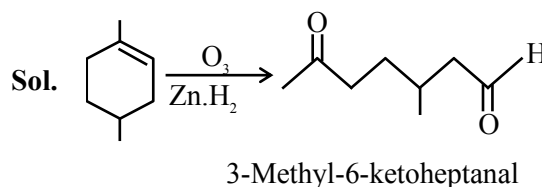

68. Match the LIST-I with LIST-II

LIST-I (Molecules/ion)		LIST-II (Hybridisation of central atom)	
A.	PF_5	I.	dsp^2
B.	SF_6	II.	sp^3d
C.	$Ni(CO)_4$	III.	sp^3d^2
D.	$[PtCl_4]^{2-}$	IV.	sp^3

Choose the **correct** answer from the options given below :

- (1) A-II, B-III, C-IV, D-I
- (2) A-IV, B-I, C-II, D-III
- (3) A-I, B-II, C-III, D-IV
- (4) A-III, B-I, C-IV, D-II

Ans. (1)

Sol. $PF_5 : 5\sigma + 0 \ell p \rightarrow sp^3d$

$SF_6 : 6\sigma + 0 \ell p \rightarrow sp^3d^2$

$Ni(CO)_4 : Ni \rightarrow 0$

In presence of ligand field :-

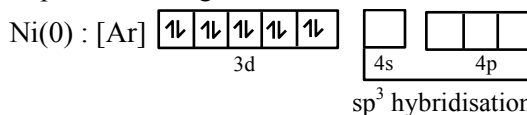

$[PtCl_4]^{2-} : Pt \rightarrow +2$

In presence of ligand field :-

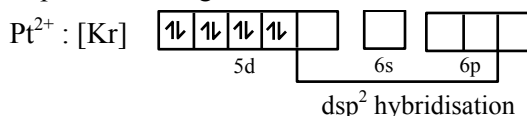

69. The least acidic compound, among the following is:

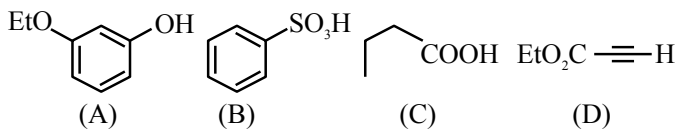

- (1) D
(2) A
(3) B
(4) C

Ans. (1)

Sol. $\text{EtO}_2\text{C}-\text{C}\equiv\text{H}$

C.B. of terminal alkyne will be sp hybridisation and localised. In other C.B. will be resonance stabilised.

70. Correct order of limiting molar conductivity for cations in water at 298 K is :

- (1) $\text{H}^+ > \text{Na}^+ > \text{K}^+ > \text{Ca}^{2+} > \text{Mg}^{2+}$
(2) $\text{H}^+ > \text{Ca}^{2+} > \text{Mg}^{2+} > \text{K}^+ > \text{Na}^+$
(3) $\text{Mg}^{2+} > \text{H}^+ > \text{Ca}^{2+} > \text{K}^+ > \text{Na}^+$
(4) $\text{H}^+ > \text{Na}^+ > \text{Ca}^{2+} > \text{Mg}^{2+} > \text{K}^+$

Ans. (2)

Sol. Limiting Molar Conductivities of Ions :

- $\text{H}^+ : 349.8 \text{ Scm}^2 \text{ mol}^{-1}$
- $\text{Na}^+ : 50.11 \text{ Scm}^2 \text{ mol}^{-1}$
- $\text{K}^+ : 73.52 \text{ Scm}^2 \text{ mol}^{-1}$
- $\text{Ca}^{+2} : 119 \text{ Scm}^2 \text{ mol}^{-1}$
- $\text{Mg}^{+2} : 106.12 \text{ Scm}^2 \text{ mol}^{-1}$

Therefore correct order of limiting molar conductivity of cations will be –

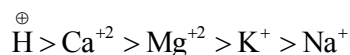

SECTION-B

71. During estimation of nitrogen by Dumas' method of compound X (0.42 g) :

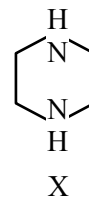

_____ mL of N_2 gas will be liberated at STP. (nearest integer)

(Given molar mass in g mol^{-1} : C : 12, H : 1, N : 14)

Ans. (11)

Sol. M.wt. of given compound = 86

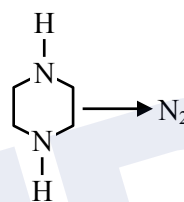

Applying POAC on 'N'

$$n_x \times 2 = n_{\text{N}_2} \times 2$$

$$\frac{0.42}{86} = n_{\text{N}_2}$$

$$\Rightarrow (\text{Volume})_{\text{N}_2} \text{ at STP} = \frac{0.42}{86} \times 22.4 \text{ L}$$

$$= 0.1108 \text{ L} = 110.8 \text{ ml}$$

72. 0.5 g of an organic compound on combustion gave 1.46 g of CO_2 and 0.9 g of H_2O . The percentage of carbon in the compound is _____. (Nearest integer)

[Given : Molar mass (in g mol^{-1}) C : 12, H : 1, O : 16]

Ans. (80)

Sol. Organic $\rightarrow \text{CO}_2$

Compound

Applying POAC on 'C'

$$(\text{mole}) \text{ of 'C' in compound} = n_{\text{CO}_2} \times 1$$

So mass of 'C' in compound

$$= \frac{1.46}{44} \times 12$$

$$\text{So, \% of 'C' in compound} = \frac{1.46}{44} \times \frac{12}{0.5} \times 100$$

$$= 79.63$$

73. The number of optical isomers exhibited by the iron complex (A) obtained from the following reaction is _____.

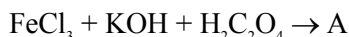

Ans. (2)

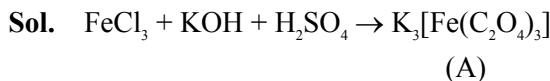

$\Rightarrow [\text{Fe}(\text{C}_2\text{O}_4)_3]^{3-}$ is $[\text{M}(\text{AA})_3]$ type complex.

So total optical isomers = 2

74. Given :

$$\Delta H_{\text{sub}}^\ominus[\text{C}(\text{graphite})] = 710 \text{ kJ mol}^{-1}$$

$$\Delta_{\text{C-H}} H^\ominus = 414 \text{ kJ mol}^{-1}$$

$$\Delta_{\text{H-H}} H^\ominus = 436 \text{ kJ mol}^{-1}$$

$$\Delta_{\text{C=C}} H^\ominus = 611 \text{ kJ mol}^{-1}$$

The ΔH_f^\ominus for $\text{CH}_2=\text{CH}_2$ is _____ kJ mol^{-1}
(nearest integer value)

Ans. (25)

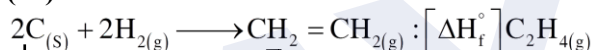

Sol.

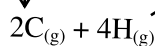

$$[\Delta H_f^\ominus]_{\text{C}_2\text{H}_{4(\text{g})}} = 2 \times [\Delta H_{\text{sub}}^\ominus]_{\text{C}_{(\text{s})}} + 2 \times \Delta H_{\text{H-H}}^\ominus - 1 \times \Delta H_{\text{C=C}}^\ominus - 4 \times \Delta H_{\text{C-H}}^\ominus$$

$$\Rightarrow [\Delta H_f^\ominus]_{\text{C}_2\text{H}_{4(\text{g})}} = (2 \times 710) + (2 \times 436) - 611 - 4 \times 414$$

$$\Rightarrow [\Delta H_f^\ominus]_{\text{C}_2\text{H}_{4(\text{g})}} = 25 \text{ kJ / mol}$$

75. Consider the following reactions

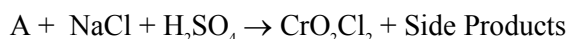

Little amount

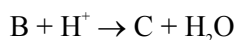

The number of terminal 'O' present in the compound 'C' is _____.

Ans. (6)

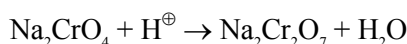
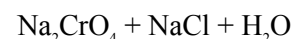
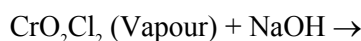
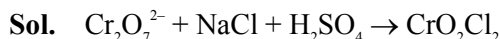

(C)

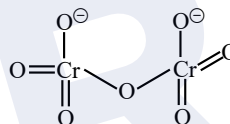

No of terminal "O" = 6